

Laboratory Manual

for

PHY2053L

January 2012

By

David Michael Judd

Laboratory Manual
for
PHY2053L

January 2012

By

David Michael Judd

Broward College

Copyright © 2007 by David Michael Judd
All rights reserved.

Table of Contents

<i>Experiment</i>	<i>Topic</i>
1	Measurement and Uncertainty
2	Addition and Resolution of Vectors
3	Projectile Motion
4	Constant Acceleration
	A Quantitative Interlude: A Mathematical Description of Circular Motion
5	Circular Motion
6	The Simple Pendulum
7	Simple Harmonic Motion
	A Quantitative Interlude: The Theory of Torques
8	Torques and Rotational Equilibrium
9	Moment of Inertia
10	The Period of A Physical Pendulum
11	The Ballistic Pendulum
12	Standing Waves on a String
	Make-Up Lab: The Thermal Coefficient of Linear Expansion

Appendices:

Graphs
Method of Least Squares
Greek Alphabet
Physical Constants

When you can measure what you are speaking about
and express it in numbers, you know something about it;
but when you cannot measure it, when you cannot express
it in numbers, your knowledge is of a meager and
unsatisfactory kind.

Lord Kelvin

And Adam knew Eve.

Book of Genesis

PHY2053 LABORATORY

Experiment One

Measurement and Uncertainty

MEASUREMENT

Physics is a quantitative, experimental, physical science. Measurement is central to experimental physics. It is beyond the scope of this course to examine all of the profound questions that arise when one takes up the philosophical problematics of measurement. However, we do need to address a few important points.

Figure One



Consider the straight line segment shown above in Figure One. Suppose you wanted to **know the length** of this line. What would you do? **Measure** it with a ruler. It is quite reasonable, when one wishes to **know the length** of something, to measure it with a ruler. Next, consider the ruler. What important property does the ruler have in common with the line segment? The important common property I was thinking of is **extension**. Both the line segment and the ruler are extended. This suggests that a measurement involves a **comparison** between two physical things, both of which have a property in common--the property we wish to measure.

As you probably have noticed, all physical things are extended. Of all of the physical things in the lab, however, the ruler is the best choice for making a measurement of length. The ruler allows us to compare an unknown length with a "known" length. The markings on the ruler are reproductions of standard units of length, or, if you will, "**known lengths**."

As an example, consider the line segment and ruler represented below in Figure Two. The distance between any two adjacent vertical lines on the ruler is the same, and that distance is our **standard unit**. So, we can say that the length of the line segment is more than three but less than four standard **units**. (In this particular case, the standard unit is the *inch*.) We **know** that the line segment is longer than three *inches* but shorter than four *inches*. We can observe that it is closer to four than three. So, using this ruler, we can estimate with confidence that the length ℓ of the line segment is given by

$$3.5 \text{ in} < \ell < 4.0 \text{ in} .$$

Figure Two

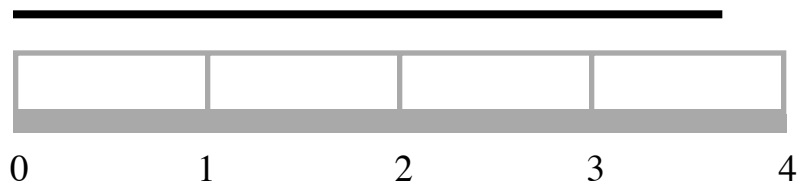

We are, however, uncertain as to its **exact length**.

A measurement, then, is a kind **comparison**--a comparison of a property held in common by two physical things. Also, among other things, a measurement is a kind of **counting**--one counts the number of standard units needed to quantify the property being measured.

Some of you may find the measurement of the line segment in Figure Two a bit untidy. You might think that we should be able to do better than saying the length of the line is slightly longer than three and one half *inches*. You would be correct, we can do better. However, to do better, we will require a smaller standard length. Consider Figure Three below.

Figure Three

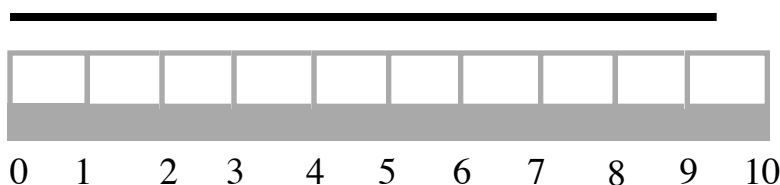

Using a ruler with smaller standard lengths, allows us to "narrow the gap" between the upper and lower limits of the measurement. Now we can say that the length of the line is between nine and ten standard units. (In this particular case, the standard length represented is a *centimeter*.) So, using this ruler, we can estimate with confidence that the length of the line segment is give by

$$9 \text{ cm} < \ell < 10 \text{ cm} .$$

We could, of course, improve our measurement by using a still smaller standard unit like the *millimeter*. But what is the exact length of the line segment? **I do not know exactly!** (Is this the same thing as saying: I do not know? Is there anything about which one can have exact knowledge?)

Uncertainty, what scientists call **experimental error**, is inherent in the measurement process. The best that we can hope to do is to specify an upper limit and a lower limit for a particular measurement. There is, however, no way to completely avoid the uncertainty in the measurement. We cannot arrive at an exact measurement, we **cannot know with certainty** the exact value of the physical quantity being measured.

Even though the uncertainty of a measurement is called experimental error, it is not to be confused with what we think of as a mistake. It is possible to make mistakes when performing an experiment. It is very desirable to identify these mistakes and eradicate them. However, even if we were able to perfect our experimental technique, we would not be able to eradicate the inherent uncertainty, the **experimental error** in the measurement process.

When we use the word "error" in the sense of a mistake, we are usually talking of a **systematic error**. For example, say we wanted to measure the mass of an object by using a scale.

If the scale indicated a value 0.1 gram when there was nothing on the scale, then the scale is improperly zeroed and every measurement would have a "built in" error of one tenth of a *gram*. We call this a systematic error. It is imperative to uncover and eradicate systematic errors. Systematic errors undermine the **accuracy** of the measurement. (We want very much for our measurements to be accurate. If, to the nearest *millimeter*, an object is 75 mm , then we want our measurement to reflect this.)

Returning to Figure Three, we could ask students to estimate the length of this line segment to the nearest tenth of a *centimeter*. In this instance, there would be no reason to expect everyone to agree; there is "room" for honest disagreement. Why? We have reached the limits of our ability to determine the length of the line segment using this specific standard unit. Student estimates of the nearest tenth of a *centimeter* would be **random errors**. Random errors do not reflect so much on the accuracy of the measurement, as on the **precision** of the measurement. The precision is telling us that if we were to repeat this measurement using the same ruler, then we could rely on getting an accurate result to the nearest *centimeter* with there being some uncertainty in determining tenths of a *centimeter*. Using this ruler, we can measure with a precision of 1 cm .

The experiments that we will be doing in this lab are fairly simple. By that I mean we will be measuring physical quantities directly. We will be measuring **lengths, masses, and time intervals**. The experimental side of research physics, however, has moved way beyond such simple types of measurement. Regardless of the sophistication of the experiment, two very important tasks confront the experimenter:

First, one must convince oneself--and the rest of the scientific community--that the experiment being performed actually measures the physical quantity desired. For example, one might wish to measure the magnitude of the electric charge on an electron, as Millikan did at the beginning of the 20th century. In such a case, one must be able to convince oneself that the measurement one makes is indeed that of the electron's electric charge and not something else altogether.

Secondly, one must identify the best experimental value of the quantity being "measured," and include a reasonable estimate of the experimental error involved in the measurement.

The second of these tasks involves what is called **error analysis**, and it can be a formidable process. **Statistics** is that branch of mathematics that deals with the complicated processes of error analysis. It is also beyond the scope of this course to introduce all of the statistics needed to carry out a thorough analysis of the errors attendant to an experimental measurement. However, we do need to understand some basic statistical concepts if we are to make **reasonable estimates** of the measured physical quantities and to make reasonable estimates of the errors involved in our scientific work.

SOME BASIC STATISTICS

The Arithmetic Mean:

Usually, the best estimate of a measured quantity is the **arithmetic mean**. The arithmetic mean assumes that each measurement value is equally valid. Assume that we have measured the length of a line segment three times with a ruler having a *millimeter* scale and that we obtained the following values:

$$\ell_1 = 195 \text{ mm} ,$$

$$\ell_2 = 196 \text{ mm} ,$$

$$\ell_3 = 197 \text{ mm} .$$

(The subscripts are used to distinguish the "measuring events." So ℓ_1 represents the first measurement value, while ℓ_2 represents the second measurement value, and so on.) For these measurements, the best estimate of the experimental value would be found by taking the arithmetic mean. I will represent the arithmetic mean by $\bar{\ell}$.

For the measurement values given, the arithmetic mean is

$$\bar{\ell} = \frac{\ell_1 + \ell_2 + \ell_3}{3} = \frac{195 \text{ mm} + 196 \text{ mm} + 197 \text{ mm}}{3} = 196 \text{ mm} .$$

So, our best estimate of the length of the line segment is $\bar{\ell} = 196 \text{ mm}$. (Mean values are often represented with short, horizontal line segments on top of the algebraic symbol representing the quantity.)

A general mathematical statement for calculating the arithmetic mean of N measured values is given by

$$\bar{X} = \frac{x_1 + x_2 + x_3 + \cdots + x_N}{N} = \frac{1}{N} \sum_{i=1}^N x_i . \quad (1)$$

Estimating the Experimental Error:

Once we have made a determination about the best estimate for our measured value, we turn our attention to the experimental error. First, note that we **can not determine the error exactly!** There is always as much uncertainty in our **"knowledge"** about the error of a measurement as there is about our knowledge of the measurement itself.

Next, we need a process by which we can arrive at a **reasonable estimate of the experimental error**. There are several such processes. However, in this introduction, I am going

to limit the discussion to the method used most often by experimental physicists. Physicists most often use a number called the **standard deviation** to estimate the experimental error.

The Standard Deviation:

To estimate the experimental error, we first look at how the actual measurement values differ from the average. To do this we use what is called **the deviation**. We can define the deviation of the i^{th} measurement by

$$d_i = x_i - \bar{X} . \quad (2)$$

Using the measurement values from the example given above, we can write:

$$d_1 = x_1 - \bar{X} = 195 \text{ mm} - 196 \text{ mm} = -1 \text{ mm} ,$$

$$d_2 = x_2 - \bar{X} = 196 \text{ mm} - 196 \text{ mm} = 0 \text{ mm} ,$$

$$d_3 = x_3 - \bar{X} = 197 \text{ mm} - 196 \text{ mm} = 1 \text{ mm} .$$

At first blush, one might think that simply taking an average of the deviations would give us a reasonable estimate of the experimental error. However, when we do generate such an average, we find

$$\begin{aligned} d_{ave} &= \frac{d_1 + d_2 + d_3 + \dots + d_N}{N} \\ &= \frac{(x_1 - \bar{X}) + (x_2 - \bar{X}) + (x_3 - \bar{X}) + \dots + (x_N - \bar{X})}{N} \\ &= \frac{x_1 + x_2 + x_3 + \dots + x_N}{N} - \frac{N\bar{X}}{N} = \bar{X} - \bar{X} = 0 . \end{aligned}$$

Of course zero is the worst estimate of the experimental error as it suggests that we are certain of our measurement.

The **standard deviation** is defined in terms of the square of the deviation. The standard deviation is represented by σ (a lower case Greek letter named *sigma*). The common form to the standard deviation is

$$\sigma = \sqrt{\frac{1}{N} \sum_{i=1}^N d_i^2} , \quad (3)$$

This formula assumes that a very large number of measurements were made. In this lab, however, we will never be measuring a specific quantity more than twelve times. So, for small sets of data, a

better formula for the standard deviation is

$$\sigma_s = \sqrt{\frac{1}{N-1} \sum_{i=1}^N d_i^2} . \quad (4)$$

If we return to the data given in our example, we have

$$\sigma_{s,\ell} = \sqrt{\left[\frac{1}{3-1} \right] \left[(0 \text{ mm})^2 + (-1 \text{ mm})^2 + (1 \text{ mm})^2 \right]} = 1.0 \text{ mm} . \quad (5)$$

(The standard deviation is almost always rounded to **one significant digit**. One important exception is if the single significant digit is the number one, then it is customary to use two significant digits.) In our example set of data, the standard deviation turns out to be one *millimeter*. This was also the assumed smallest standard unit of the measuring devise. We call the smallest standard unit used in a measurement the **least count**. The least count is always a quick, useful way to reasonably estimate error.

One final complicating point. In this example we have estimated the measurement error to be one *millimeter*; this value represents what is referred to as the **absolute error**. There are, however, times when the specification of the absolute error is not all that helpful. For example, if we were able to measure the diameter of the Earth to $\pm 1 \text{ mm}$, we would have done a wonderful job of measurement. On the other hand, such an absolute error would be much less impressive if it were associated with a measurement of the thickness of a single sheet of paper. In many instances, then, it is more helpful to use the **relative error**. The relative error is the ratio of the absolute error to the mean measured value. Using the standard deviation we have:

$$\varepsilon = \frac{\sigma}{\bar{X}} . \quad (6)$$

We can easily represent the relative error as a percentage by multiplying by one hundred percent. So, we have

$$\varepsilon_{\%} = (100)\varepsilon . \quad (7)$$

For our simple example then, the relative error would be

$$\varepsilon = \frac{\sigma_{s,\ell}}{\bar{\ell}} = \frac{1.0 \text{ mm}}{196 \text{ mm}} = 0.005 , \quad (8)$$

and as a percentage

$$\varepsilon_{\%} = (100)(0.005) = 0.5\% . \quad (9)$$

For our example, then, we have

$$\ell = \bar{\ell} \pm \sigma_{s,\ell} , \quad (10)$$

where $\bar{\ell}$ is our best estimate of the true value of the length of the line segment and $\sigma_{s,\ell}$ is our estimate of the experimental error.

Mathematicians have demonstrated that if one makes a large number of measurements for a truly random process--a process subject to random errors only--then the standard deviation will also tell us something about how the measurement values should be distributed with respect to the mean. This distribution is called the normal distribution, sometimes, also called the bell curve. One such normal distribution is represented below in Figure Four. For a normal distribution, one would expect that about 68% of the measurements would be within $\pm 1 \sigma$ of the mean, and that about 95% of the measurements would be within $\pm 2 \sigma$ of the mean.

Figure Four
The Normal Distribution

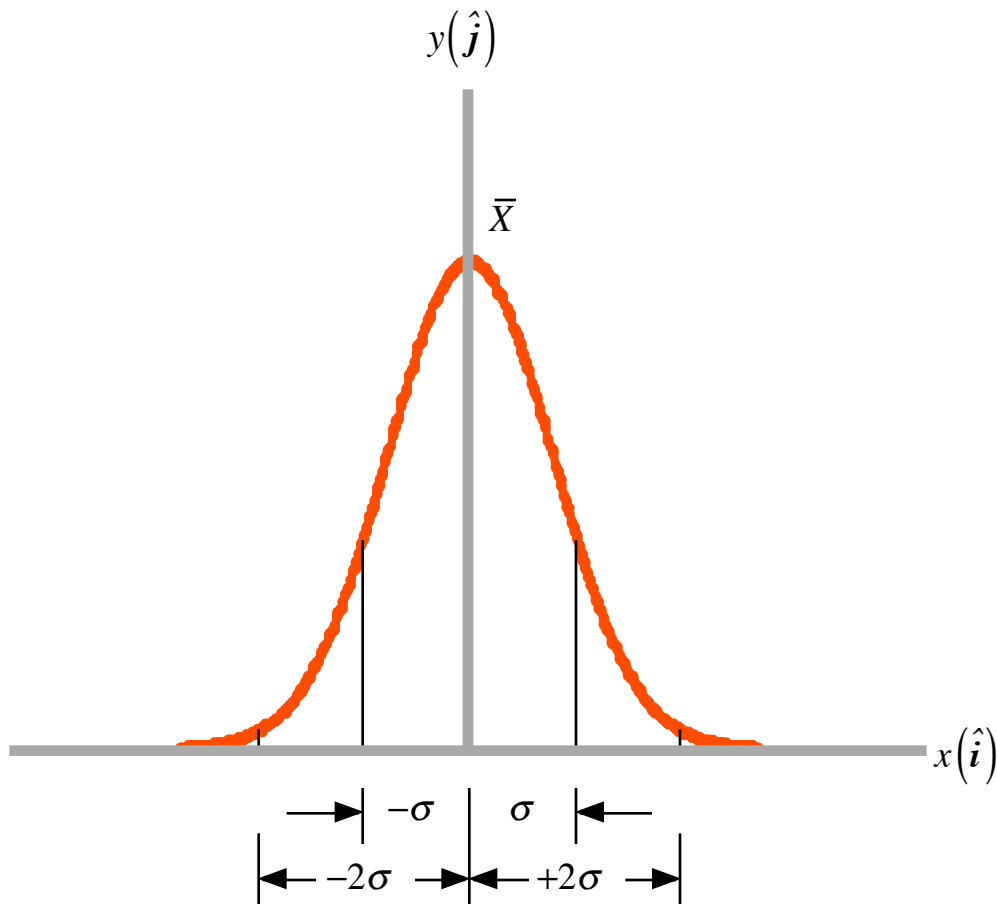

The Percent Error:

In this lab, there will be times when we will want to compare our experimental result with an already well established experimental value. In such an event, we use the so-called **percent error**. The percent error is defined by

$$\%Error \equiv \left| \frac{E - A}{A} \right| (100) , \quad (11)$$

where E represents our experimental value and A represents the experimentally accepted value.

The Percent Difference:

There will be times in this lab when we will be interested in comparing one measurement of a physical quantity with a second measurement of the same physical quantity. In this case, we will use the so-called **percent difference** between the experimental values. The percent difference between two values N_1 and N_2 is defined by

$$\%Difference \equiv \left| \frac{N_1 - N_2}{N_{ave}} \right| (100) = \left| \frac{N_1 - N_2}{(N_1 + N_2)/2} \right| (100) = \left| \frac{N_1 - N_2}{N_1 + N_2} \right| (200) . \quad (12)$$

Significant Figures:

Above, we discussed three measurements of the length of a line segment obtained using a ruler with a *millimeter* scale. We found the arithmetic mean to be $\bar{\ell} = 196 \text{ mm}$. The experimental error is estimated to be $\sigma_{s,\ell} = 1 \text{ mm}$. We could write this as $\ell = 196(1) \text{ mm}$, where the number in the parenthesis is telling us about the error. The precision of a measurement is determined by the measuring apparatus. Now I could write this number in terms of the standard *SI* unit the *meter*. We would have $\ell = 0.196(1) \text{ m}$. Since the measuring apparatus used only allows us to measure with a precision of one one-thousandth of a *meter*, it would be incorrect to write this as 0.1960000 m even though I might be able to display it as such on my calculator. We always want the digits that we write down for a measured value to correctly represent the precision of the measurement. We accomplish this by paying close attention to the number of significant digits or significant figures we write down. If I measure the mass of an object on a scale that is only capable of measuring to the nearest tenth of a *gram*, then it would be incorrect to write something like 23.343 grams . Rather, we would have $23.3(1) \text{ grams}$, three significant figures

not five!

What do we do when we have to perform arithmetic operations involving measured values? We follow the following guidelines:

Addition: "Line up" the decimal points and keep the fewest significant digits to the right of the decimal point as found in any single addend. What? For example, let us say we want the sum of the following lengths measured in *meters*:

$$\begin{array}{r} 245.26 \quad m \\ 12.3560 \quad m \\ 5.4451 \quad m \\ \hline 246.06 \quad m \end{array}$$

Note, we only keep two places to the right of the decimal point as that is the fewest digits to the right of any of the addend values--in this case the first addend.

Multiplication or Division: In general, we round the result to the smallest number of significant figures contained in any factor. For example,

$$(124.56 \text{ cm})(156.7 \text{ cm}) = 19518.55200 \text{ cm}^2$$

according to the display on my TI-85 ®. However, since one of the factors has only four significant figures, while the other has five, we round to four significant figures and we write this as

$$(124.56 \text{ cm})(156.7 \text{ cm}) = 19520 \text{ cm}^2 = 1.952 \times 10^4 \text{ cm}^2 .$$

Another customary rule to remember is that when the first digit of your result is a one, then add another significant figure. For example, write $(3)(0.34) = 1.02$ not 1.0.

ERROR ANALYSIS

To illustrate how we do a typical error analysis, assume that we have made five measurements of the length ℓ , width w and height h of a table top, as represented below in Figure Five.

We construct a table which includes the measurements, the absolute deviation of each measurement from the arithmetic mean, and the square of each deviation. First, consider the length data shown in the table below. From the measurements, we first calculate the arithmetic mean length. We find

$$\bar{\ell} = \frac{9.284 \text{ m}}{5} = 1.857 \text{ m} . \quad (13)$$

Next, we calculate the standard deviation for our length measurements and find

$$\sigma_{s,\ell} = \sqrt{\left[\frac{1}{5-1}\right] \left[15 \times 10^{-6} m^2\right]} = 0.0019 m = 0.002 m. \quad (14)$$

Length Data

N	$\ell_i (m)$	$ d_i (m)$	$d_i^2 (\mu m^2)$
1	1.857	0	0
2	1.859	0.002	4
3	1.854	0.003	9
4	1.856	0.001	1
5	1.858	0.001	1
<i>Sums :</i>	9.284		15

Figure Five

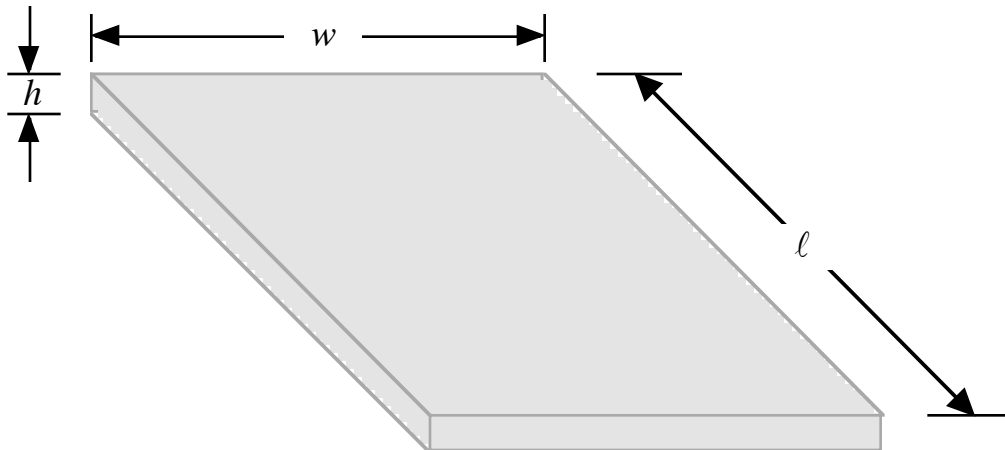

The relative error would be given by

$$\varepsilon_\ell = \frac{\sigma_{s,\ell}}{\bar{\ell}} = \frac{.002}{1.857} = 1.1 \times 10^{-3}. \quad (15)$$

So, we can write for the length that

$$\ell = \bar{\ell} \pm \sigma_{s,\ell} = 1.857 \text{ m} \pm 0.002 \text{ m} . \quad (16)$$

Our best estimate of the length is $\bar{\ell} = 1.857 \text{ m}$ and a reasonable estimate of the absolute error is $\sigma_{s,\ell} = 0.002 \text{ m}$.

We can follow a similar process with the width data and the data for the height. For the mean width we have

$$\bar{w} = \frac{6.023 \text{ m}}{5} = 1.205 \text{ m} . \quad (17)$$

For the standard deviation, we have

$$\sigma_{s,w} = \sqrt{\left[\frac{1}{5-1} \right] \left[6 \times 10^{-6} \text{ m}^2 \right]} = 0.0012 \text{ m} = 0.001 \text{ m} . \quad (18)$$

The relative error is

$$\varepsilon_w = \frac{\sigma_{s,w}}{\bar{w}} = \frac{.001}{1.205} = 8.3 \times 10^{-4} . \quad (19)$$

Width Data

N	$\ell_i \text{ (m)}$	$ d_i \text{ (m)}$	$d_i^2 \text{ (}\mu\text{m}^2\text{)}$
1	1.203	0.002	4
2	1.205	0	0
3	1.204	0.001	1
4	1.205	0	0
5	1.206	0.001	1
<i>Sums :</i>	6.023		6

So, for the width, we can write

$$w = \bar{w} \pm \sigma_{s,w} = 1.205 \text{ m} \pm 0.001 \text{ m} , \quad (20)$$

where our best estimate of the width is $\bar{w} = 1.205 \text{ m}$ and a reasonable estimate of the absolute error is $\sigma_{s,w} = 0.001 \text{ m}$.

For the height, we find the mean height to be

$$\bar{h} = \frac{0.126 \text{ m}}{5} = 0.025 \text{ m} . \quad (21)$$

The standard deviation of the height is given by

$$\sigma_{s,h} = \sqrt{\left[\frac{1}{5-1} \right] \left[3 \times 10^{-6} \text{ m}^2 \right]} = 0.00087 \text{ m} = 0.001 \text{ m} . \quad (22)$$

The relative error, then, is given by

$$\varepsilon_h = \frac{\sigma_{s,h}}{\bar{h}} = \frac{.001}{0.025} = 4.0 \times 10^{-2} . \quad (23)$$

Note that the relative error of the height is about forty times greater than that of the length and the width!

For the height, then, we have

$$h = \bar{h} \pm \sigma_{s,h} = 0.025 \text{ m} \pm 0.001 \text{ m} . \quad (24)$$

Our best estimate of the height is $\bar{h} = 0.025 \text{ m}$ and a reasonable estimate of the error is $\sigma_{s,h} = 0.001 \text{ m}$.

Height Data

N	$\ell_i (m)$	$ d_i (m)$	$d_i^2 (\mu\text{m}^2)$
1	0.025	0	0
2	0.026	0.001	1
3	0.024	0.001	1
4	0.026	0.001	1
5	0.025	0	0
<i>Sums :</i>	0.126		3

These measurements were made with a ruler the smallest standard unit of which is a *millimeter*. It is reasonable that our errors would be close to this standard unit. (As I mentioned above, it is often simplest to use the “**least count**” to estimate errors. For serious scientific work, however, one usually has much more data than five measurements and, as it is desirable to neither underestimate nor overestimate the error, one uses the standard deviation to estimate the error.)

THE PROPAGATION OF ERROR

The Propagation of Errors in Addition or Subtraction:

Now that we have made measurements of the length, width and height of our phantom table top, we want to know how our error in these measurements would affect our estimate of the **perimeter** of the table top. So, we can write

$$\ell = \bar{\ell} \pm \sigma_{s,\ell} . \quad (25)$$

and
$$w = \bar{w} \pm \sigma_{s,w} . \quad (26)$$

The perimeter is given by

$$\begin{aligned} P &= \bar{P} \pm \sigma_{s,P} = 2(\ell + w) = 2\left[\left(\bar{\ell} \pm \sigma_{s,\ell}\right) + \left(\bar{w} \pm \sigma_{s,w}\right)\right] \\ &= 2\left[\left(\bar{\ell} + \bar{w}\right) \pm \left(\sigma_{s,\ell} + \sigma_{s,w}\right)\right] = 2\left(\bar{\ell} + \bar{w}\right) \pm 2\left(\sigma_{s,\ell} + \sigma_{s,w}\right) = \bar{P} \pm \sigma_{s,P} , \end{aligned} \quad (27)$$

So, our best estimate of the perimeter is

$$\bar{P} = 2\left(\bar{\ell} + \bar{w}\right) = 2(1.857 \text{ m} + 1.205 \text{ m}) = 6.124 \text{ m} . \quad (28)$$

A reasonable estimate of the error would be

$$\begin{aligned} \sigma_{s,P} &= 2\left(\sigma_{s,\ell} + \sigma_{s,w}\right) \\ \sigma_{s,P} &= 2(0.002 \text{ m} + 0.001 \text{ m}) = 2(0.003 \text{ m}) = 0.006 \text{ m} . \end{aligned} \quad (29)$$

For the perimeter, then, we have

$$P = 6.124 \text{ m} \pm 0.006 \text{ m} . \quad (30)$$

We conclude that **for addition and subtraction**, the **absolute errors simply add**.

That analysis was straightforward and gives us a reasonable estimate of the error. However, the mathematicians tell us that it slightly overestimates the error. They suggest that for addition or subtraction a better estimate of the error is given by

$$\sigma_{s,P} = \sqrt{\sigma_{s,\ell}^2 + \sigma_{s,w}^2} = \sqrt{(0.002 \text{ m})^2 + (0.001 \text{ m})^2} = 0.002 \text{ m} , \quad (31)$$

The Propagation of Error in Multiplication:

To see how the error propagates in multiplication, let us find the **area of our phantom table top**. We use an expression of the form

$$A = \ell w = (\bar{\ell} \pm \sigma_{s,\ell}) (\bar{w} \pm \sigma_{s,w}) = \bar{\ell}\bar{w} \pm \bar{\ell}\sigma_{s,w} \pm \bar{w}\sigma_{s,\ell} \pm \sigma_{s,\ell}\sigma_{s,w} . \quad (32)$$

First, we assume that we can ignore the $\pm \sigma_{s,\ell}\sigma_{s,w}$ in equation (32) as we expect it to be much, much smaller than any of the other terms. So, we now have

$$A = \ell w = \bar{\ell}\bar{w} \pm \bar{\ell}\sigma_{s,w} \pm \bar{w}\sigma_{s,\ell} . \quad (33)$$

Next, we factor out $\bar{\ell}\bar{w}$ from equation (33) and we get

$$A = \ell w = \bar{\ell}\bar{w} \left[1 \pm \frac{\sigma_{s,w}}{\bar{w}} \pm \frac{\sigma_{s,\ell}}{\bar{\ell}} \right] = \bar{\ell}\bar{w} [1 \pm (\varepsilon_\ell + \varepsilon_w)] = \bar{A} [1 \pm \varepsilon_A] , \quad (34)$$

where

$$\bar{A} = \bar{\ell}\bar{w} , \quad (35)$$

and

$$\varepsilon_A = \varepsilon_\ell + \varepsilon_w . \quad (36)$$

This analysis suggests that the relative error of the area is the sum of the relative errors of the length and width. The mathematicians tell us, however, that this overestimates the error and that a better estimate is given by

$$\varepsilon_A = \sqrt{\varepsilon_\ell^2 + \varepsilon_w^2} . \quad (37)$$

From this, we can, of course get the absolute error using

$$\sigma_{s,A} = \bar{A}\varepsilon_A . \quad (38)$$

Using our data for our hypothetical table top, we have

$$\bar{A} = \bar{\ell}\bar{w} = (1.857 \text{ m})(1.205 \text{ m}) = 2.238 \text{ m}^2 , \quad (39)$$

and a reasonable estimate of the error would be

$$\begin{aligned} \sigma_{s,A} &= \bar{A}\varepsilon_A = \bar{A}\sqrt{\varepsilon_\ell^2 + \varepsilon_w^2} \\ &= (2.238 \text{ m}^2) \sqrt{(1.1 \times 10^{-3})^2 + (0.83 \times 10^{-3})^2} = 0.003 \text{ m}^2 . \end{aligned} \quad (40)$$

So, we could write

$$A = \bar{A} \pm \sigma_{s,A} = 2.238 \text{ m}^2 \pm 0.003 \text{ m}^2 . \quad (41)$$

In a similar fashion, if we wanted to estimate the volume of our imaginary table top, we would write

$$V = \bar{V} \pm \sigma_{s,V}, \quad (42)$$

where

$$\bar{V} = \bar{\ell}\bar{w}\bar{h} = (1.857 \text{ m})(1.205 \text{ m})(0.025 \text{ m}) = 0.056 \text{ m}^3, \quad (43)$$

and

$$\begin{aligned} \sigma_{s,V} &= \bar{V}\epsilon_V = \bar{V}\sqrt{\epsilon_\ell^2 + \epsilon_w^2 + \epsilon_h^2} \\ &= (0.056 \text{ m}^3)\sqrt{(1.1 \times 10^{-3})^2 + (0.83 \times 10^{-3})^2 + (40 \times 10^{-3})^2} = 0.002 \text{ m}^3. \end{aligned} \quad (44)$$

So,

$$V = 0.056 \text{ m}^3 \pm 0.002 \text{ m}^3. \quad (45)$$

The Propagation of Error in Division:

To see how the error propagates in division, we consider an experiment where we have N measurements of a distance ℓ , and N measurements of the time interval t over which the distance was traversed by a moving object. We wish to calculate the **magnitude** of the average velocity of this object. So, we can write

$$\ell = \bar{\ell} \pm \sigma_{s,\ell} = \bar{\ell} \left[1 \pm \left(\sigma_{s,\ell} / \bar{\ell} \right) \right] = \bar{\ell} (1 \pm \epsilon_\ell), \quad (46)$$

$$t = \bar{t} \pm \sigma_{s,t} = \bar{t} \left[1 \pm \left(\sigma_{s,t} / \bar{t} \right) \right] = \bar{t} (1 \pm \epsilon_t), \quad (47)$$

and
$$v_{ave} = \bar{v}_{ave} \pm \sigma_{s,v_{ave}} = \bar{v}_{ave} \left[1 \pm \left(\sigma_{s,v_{ave}} / \bar{v}_{ave} \right) \right] = \bar{v}_{ave} (1 \pm \epsilon_{v_{ave}}). \quad (48)$$

By formula, we write

$$v_{ave} = \frac{\ell}{t} = \frac{\bar{\ell}(1 \pm \epsilon_\ell)}{\bar{t}(1 \pm \epsilon_t)} = \left[\frac{\bar{\ell}}{\bar{t}} \right] \frac{(1 \pm \epsilon_\ell)}{(1 \pm \epsilon_t)}. \quad (49)$$

Unlike with multiplication, for division, the error is a maximum when the relative errors in the numerator are added while those in the denominator are subtracted. So, using this condition and Newton's binomial theorem, we can approximate equation (49) with

$$v_{ave} = \left[\frac{\bar{\ell}}{\bar{t}} \right] (1 \pm \epsilon_\ell)(1 \mp \epsilon_t)^{-1}, \quad (50)$$

and

$$v_{ave} \approx \left[\frac{\bar{\ell}}{\bar{t}} \right] \left[1 \pm (\epsilon_\ell + \epsilon_t) \right]. \quad (51)$$

Comparison of equations (48) and (51) suggests that the best estimate of the magnitude of the average velocity is found by

$$\bar{v}_{ave} = \frac{\bar{\ell}}{\bar{t}}, \quad (52)$$

while a reasonable estimate of the error in this calculation would be given by

$$\sigma_{s,v_{av3}} = \bar{v}_{ave} \epsilon_{v_{ave}} = \bar{v}_{ave} (\epsilon_\ell + \epsilon_t). \quad (53)$$

So, **in division**, the **relative error** is the **sum of the relative errors of each of the factors in the dividend and the divisor**.

Propagation of error with an exponential:

We now look at how error propagates when a measurement is raised to some exponential power. Assume the side length a of a cube has been measured N times with the results expressed as

$$a = \bar{a} \pm \sigma_{s,a} = \bar{a} \left[1 \pm \frac{\sigma_{s,a}}{\bar{a}} \right] = \bar{a} [1 \pm \epsilon_a]. \quad (54)$$

Now, if we wanted to determine the best estimate for the volume of the cube, we would have

$$\begin{aligned} V = \bar{V} \pm \sigma_{s,V} &= \bar{V} \left[1 \pm \frac{\sigma_{s,V}}{\bar{V}_c} \right] = \bar{V} [1 \pm \epsilon_V] = a^3 = [\bar{a}(1 \pm \epsilon_a)]^3 = \bar{a}^3 (1 \pm \epsilon_a)^3 \\ &= \bar{a}^3 (1 \pm 3\epsilon_a \pm 3\epsilon_a^2 \pm \epsilon_a^3). \end{aligned} \quad (55)$$

Again, we employ the fact that the product of relative errors is usually small enough to ignore, that is

$$\epsilon_a^2 \approx \epsilon_a^3 \approx 0. \quad (56)$$

We can, therefore, write equation (55) as

$$V = \bar{V} \pm \sigma_{s,V} = \bar{V} (1 \pm \epsilon_V) = \bar{a}^3 (1 \pm \epsilon_a)^3 \approx \bar{a}^3 (1 \pm 3\epsilon_a). \quad (57)$$

So, the best estimate of the volume of the cube would be

$$\bar{V} = \bar{a}^3, \quad (58)$$

and a reasonable estimate of the error of the measure of the cube would be

$$\sigma_{s,V} = \bar{V} \varepsilon_V = \bar{V} (3\varepsilon_a) = \bar{a}^3 (3\varepsilon_a) . \quad (59)$$

We conclude then that a reasonable estimate of the relative error involved in a measurement of some physical quantity x raised to the n^{th} power is given by

$$\varepsilon = n\varepsilon_x . \quad (60)$$

Summary

Mathematicians have shown that a slightly better estimate of the errors is to use the following forms:

For **Sums and Differences** of N addends, we can write:

$$\sigma_{tot} = \sqrt{(\sigma_1)^2 + (\sigma_2)^2 + \dots + (\sigma_N)^2} , \quad (61)$$

where σ_i is the standard deviation of the i^{th} addend.

For **Products and Quotients** of N factors, we can write:

$$\varepsilon_{tot} = \sqrt{(\varepsilon_1)^2 + (\varepsilon_2)^2 + \dots + (\varepsilon_N)^2} , \quad (62)$$

where ε_i is the relative error of the i^{th} factor. From this we can get the error by multiplying the relative error by the mean value. Recall the definition of the relative error is given by

$$\varepsilon = \frac{\sigma}{\bar{X}} \quad (63)$$

which implies

$$\sigma = \varepsilon \bar{X} . \quad (64)$$

PHY2053 LABORATORY

Experiment One

Measurement and Uncertainty

Name:

Date:

Day and Time:

EQUIPMENT NEEDED

One Two-meter Stick

One One-foot Ruler (with a *millimeter* scale)

PROCEDURE

Note: There should be three or four of you seated at your lab table. Each one of you is to perform each of the measurements described below **by yourself**. When each of you has finished, you will then pool your data and each of you then will calculate the statistical quantities of interest. **Please be careful with the meter sticks. Do not twirl the sticks and do not impale others with the sticks. Be especially careful with the instructor!**

- 1.) Measure the length ℓ of your lab table to the nearest *millimeter* at three different locations on the table--see Figure Six below--and record these values on your data sheet.
- 2.) Measure the width w of your lab table to the nearest *millimeter* at three different locations on the table--see Figure Six below--and record these values on your data sheet.
- 3.) Measure the height h of your lab table to the nearest *millimeter* at three different locations on the table--see Figure Six below--and record these values on your data sheet.

Figure Six
A Pictorial Representation of the Top of Your Lab Table

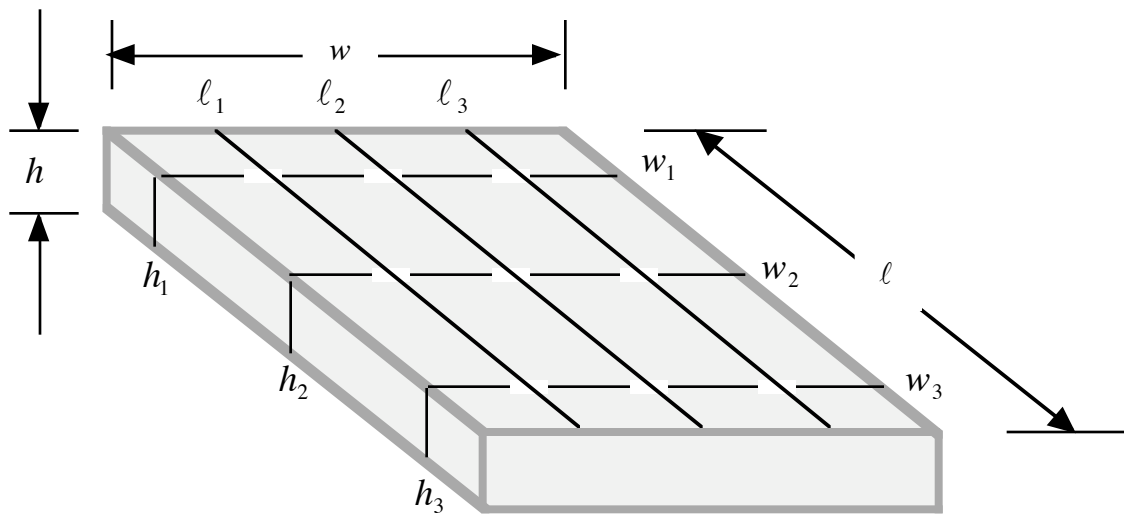

THINGS TO DO

- 1.) Add to your data sheet the measured values for the length, width and height of your table top found by the others at your table. This should give you nine or twelve measurements for each quantity. These measurements will provide the data for doing the basic statistical calculations described next.
- 2.) Using your measurement data, calculate the **arithmetic mean** $\bar{\ell}$ for the length of your table top, and record this value on your data sheet.
- 3.) Using your measurement data, calculate the **arithmetic mean** \bar{w} for the width of your table top, and record this value on your data sheet.
- 4.) Using your measurement data, calculate the **arithmetic mean** \bar{h} for the height of your table top, and record this value on your data sheet.
- 5.) Using your measurement data, calculate the standard deviation of the length of your table top $\sigma_{s,\ell}$ and record this value on the data sheet.
- 6.) Using your measurement data, calculate the standard deviation of the width of your table top $\sigma_{s,w}$ and record this value on the data sheet.
- 7.) Using your measurement data, calculate the standard deviation of the height of your table top $\sigma_{s,h}$ and record this value on the data sheet.
- 8.) Calculate the relative error of your measurement of the length of your table top ϵ_{ℓ} and record this value on the data sheet.
- 9.) Calculate the relative error of your measurement of the width of your table top ϵ_w and record this value on the data sheet.
- 10.) Calculate the relative error of your measurement of the height of your table top ϵ_h and record this value on the data sheet.
- 11.) Using your data, calculate the best estimate of the **area** of your table top \bar{A}_{top} and determine the best estimate of the error of this measurement $\sigma_{s,A}$. Record these values on the data sheet.
- 12.) Using your data, calculate the best estimate of the **volume** of your table top \bar{V}_{top} and determine the best estimate of the error of this measurement $\sigma_{s,V}$. Record these values on the data sheet.

Experimental Error

Arithmetic Mean:

If one makes N measurements of a specific physical quantity with the values

$$x_1, x_2, x_3, \dots, x_i, \dots, x_N,$$

then the best estimate of the measured value is given by the arithmetic mean. The arithmetic mean is signified by \bar{X} and calculated by

$$\bar{X} = \frac{1}{N} \sum_{i=1}^N x_i = \frac{1}{N} [x_1 + x_2 + x_3 + \dots + x_N]. \quad (1)$$

Estimate of the Absolute Error:

a) The simplest reasonable estimate of the absolute error of a set of data is the so-called **least count**. We can signify this by e_{LC} . The least count is most simply expressed as the smallest standard unit incorporated by the measuring device. For example, for a meter stick with millimeter marks as the smallest, then the least count would be $e_{LC} = 0.001 \text{ m} \equiv 1 \text{ mm}$.

b) A second reasonable way to estimate the absolute error is with the **mean absolute deviation**. The i th deviation from the mean is given by

$$d_i = x_i - \bar{X}. \quad (2)$$

The mean absolute deviation is signified by \bar{d} , and given by

$$\bar{d} = \frac{1}{N} \sum_{i=1}^N |d_i| = \frac{1}{N} [|d_1| + |d_2| + |d_3| + \dots + |d_N|]. \quad (3)$$

c) The most common estimate for the absolute error is the **standard deviation**. The standard deviation is signified by

$$\sigma = \sqrt{\frac{1}{N} \sum_{i=1}^N d_i^2} = \sqrt{\frac{1}{N} [d_1^2 + d_2^2 + d_3^2 + \dots + d_N^2]}. \quad (4)$$

The standard deviation assumes the data is a very large set of measurements of a random process. In this lab, we will never have a large set of data. For **small sets** of data, a better estimate of the standard deviation is given by

$$\sigma_s = \sqrt{\frac{1}{N-1} \sum_{i=1}^N d_i^2} = \sqrt{\frac{1}{N-1} [d_1^2 + d_2^2 + d_3^2 + \dots + d_N^2]}. \quad (5)$$

(Absolute errors in this lab will always have only one significant digit!)

The Relative Error:

Sometimes the **relative error** is more useful than the absolute error. The relative error is signified by ε . For the least count, the relative error is

$$\varepsilon = \frac{e_{LC}}{\bar{X}}, \quad (6)$$

while for the standard deviation of a small set of data we have

$$\varepsilon = \frac{\sigma_s}{\bar{X}}. \quad (7)$$

Propagation of Error:

When we perform arithmetic operations with measured quantities, it is useful to know how the error propagates. We no more wish to overestimate the error than we want to underestimate the error.

For Sums and Differences

The mathematicians tell us, then, that for adding or subtracting N different physical quantities, the absolute error goes as the square root of the sum of the squares of the absolute errors. So,

$$\sigma_{tot} = \sqrt{\sigma_1^2 + \sigma_2^2 + \sigma_3^2 + \dots + \sigma_N^2} . \quad (8)$$

For Products and Quotients

For multiplying and dividing N factors, the relative error goes as the square root of the sum of the squares of the relative errors.

$$\varepsilon_{tot} = \sqrt{\varepsilon_1^2 + \varepsilon_2^2 + \varepsilon_3^2 + \dots + \varepsilon_N^2} . \quad (9)$$

The absolute error would then be given by

$$\sigma_{tot} = \varepsilon_{tot} \bar{X} . \quad (10)$$

Examples:

Assume we have the following data on the length, the width and the height of a rectangular prism.

$$\ell = \bar{\ell} \pm \sigma_{s,\ell} = 1.853 \text{ m} \pm 0.001 \text{ m} , \quad (11)$$

$$w = \bar{w} \pm \sigma_{s,w} = 1.374 \text{ m} \pm 0.001 \text{ m} , \quad (12)$$

$$h = \bar{h} \pm \sigma_{s,h} = 0.024 \text{ m} \pm 0.001 \text{ m} . \quad (13)$$

The **perimeter of the top** would be given by

$$P = \bar{P} \pm \sigma_{s,P} , \quad (14)$$

where

$$\bar{P} = 2(\bar{\ell} + \bar{w}) = 2[1.853 \text{ m} + 1.374 \text{ m}] = 6.454 \text{ m} , \quad (15)$$

and

$$\sigma_{s,P} = \sqrt{\sigma_{s,\ell}^2 + \sigma_{s,w}^2} = \sqrt{(0.001 \text{ m})^2 + (0.001 \text{ m})^2} = 0.001 \text{ m} . \quad (16)$$

The **area of the top** would be given by

$$A = \bar{A} \pm \sigma_{s,A} , \quad (17)$$

where

$$\bar{A} = \bar{\ell}\bar{w} = (1.853 \text{ m})(1.374 \text{ m}) = 2.546 \text{ m}^2 , \quad (18)$$

and

$$\varepsilon_{s,A} = \sqrt{\varepsilon_{\ell}^2 + \varepsilon_w^2} = \sqrt{(0.001/1.853)^2 + (0.001/1.374)^2} = 9.06 \times 10^{-4} , \quad (19)$$

and

$$\sigma_{s,A} = \varepsilon_A \bar{A} = (9.06 \times 10^{-4})(2.546 \text{ m}^2) = 0.002 \text{ m}^2 . \quad (20)$$

Length Data

i	ℓ_i	$ d_{i,\ell} $	$ d_{i,\ell} ^2$
1			
2			
3			
4			
5			
6			
7			
8			
9			
10			
11			
12			

$$\bar{\ell} = \frac{1}{N} \sum_{i=1}^N \ell_i = \underline{\hspace{4cm}}$$

$$\sigma_{s,\ell} = \sqrt{\frac{1}{N-1} \sum_{i=1}^N |d_{i,\ell}|^2} = \underline{\hspace{4cm}}$$

where, recall, $d_{i,\ell} = \ell_i - \bar{\ell}$.

$$\varepsilon_\ell = \frac{\sigma_{s,\ell}}{\bar{\ell}} = \underline{\hspace{4cm}}$$

Width Data

i	w_i	$ d_{i,w} $	$ d_{i,w} ^2$
1			
2			
3			
4			
5			
6			
7			
8			
9			
10			
11			
12			

$$\bar{w} = \frac{1}{N} \sum_{i=1}^N w_i = \underline{\hspace{10em}}$$

$$\sigma_{s,w} = \sqrt{\frac{1}{N-1} \sum_{i=1}^N |d_{i,w}|^2} = \underline{\hspace{10em}}$$

where, recall, $d_{i,w} = w_i - \bar{w}$.

$$\varepsilon_w = \frac{\sigma_{s,w}}{\bar{w}} = \underline{\hspace{10em}}$$

Height Data

i	h_i	$ d_{i,h} $	$ d_{i,h} ^2$
1			
2			
3			
4			
5			
6			
7			
8			
9			
10			
11			
12			

$$\bar{h} = \frac{1}{N} \sum_{i=1}^N h_i = \underline{\hspace{10em}}$$

$$\sigma_{s,h} = \sqrt{\frac{1}{N-1} \sum_{i=1}^N |d_{i,h}|^2} = \underline{\hspace{10em}}$$

where, recall, $d_{i,h} = h_i - \bar{h}$.

$$\varepsilon_h = \frac{\sigma_{s,h}}{\bar{h}} = \underline{\hspace{10em}}$$

In the space below, determine the best estimate of the area of the top of your table. Also, estimate the error involved in your measurement of the area of the table top.

In the space below, determine the best estimate of the volume of the top of your table. Also, estimate the error involved in your measurement of the volume of the table top.

PHY2053 LABORATORY

Experiment Two

Addition and Resolution of Vectors

PROLEGOMENA

Forces are vector quantities and, as such, exhibit all of the properties of vectors. In this experiment, we will investigate **how forces add**, and thereby, how vectors add. An understanding of force is one of the central aims of this course. Although we have not formally introduced the concept of a force in the lecture, we will attempt to make some sense of what a force is. The central aim of this exercise is to demonstrate that **vectors do not add like scalar quantities**.

Since a force is a vector quantity, it has a magnitude and a direction. In keeping with the notation we use in the lecture, we can write

$$\vec{F} = F \hat{F} \quad , \quad (1)$$

where F represents the magnitude of force \vec{F} , and \hat{F} is a **unit vector** which represents the direction of force \vec{F} . We are going to use a force table to measure the magnitude and the direction of some small forces; **small weights**, to be more precise.

In Figure One below, I have represented a side view of a force table with a single mass M hanging from a thread which passes over a pulley. One end of the thread is attached to the mass and the other end of the thread is attached to a small circular ring. The thread is draped over a small pulley. The pulley is attached to the force table by means of a clamp. The vertical post on top of the force table passes through the ring.

Figure One

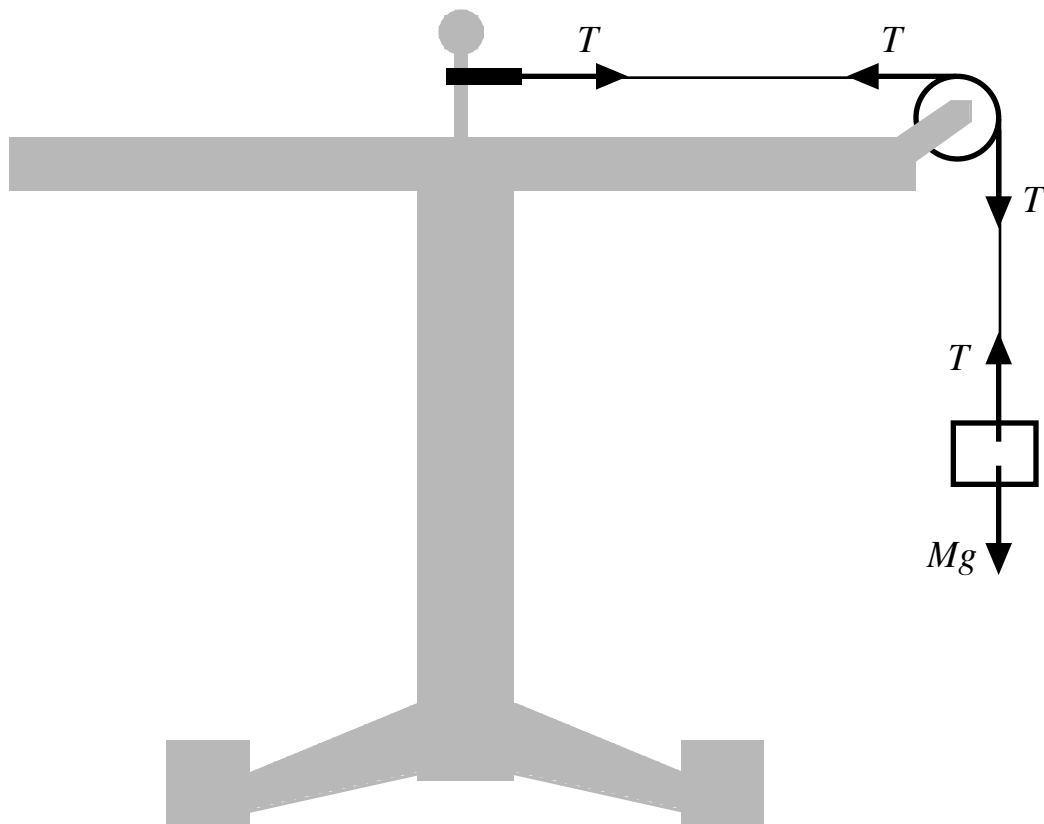

Consider the hanging mass M . There is a force exerted on this mass by the Earth. The magnitude of this force is Mg and the force is directed toward the center of the Earth. The only other significant force on this mass is the force exerted on it by the thread. This force is due to the tension in the thread and it has a magnitude $T = Mg$ and it is directed away from the center of the Earth. (The quantity g is called the acceleration due to gravity and has a value in MKS units given by $g = 9.789 \text{ m/s}^2$.)

We are going to treat the pulley as frictionless at those points where the thread makes contact with the pulley. Therefore, all the frictionless pulley does is change the direction of the tensile force exerted by the string. (Later in the semester we will introduce a more sophisticated model of a pulley.)

The thread exerts a force on the circular ring with a magnitude $T = Mg$ in a direction along the string and away from the vertical post. The vertical post exerts a force on the circular ring with a magnitude of T in the opposite direction of the string. The force exerted on the ring by the post balances the force exerted on the ring by the thread and keeps the system in **static equilibrium**. We sometimes call such balancing forces “**equilibrating**” forces.

Essentially, all of the forces exerted on the ring in this experiment will be parallel to the plane of the top of the force table, and, as such, will be two-dimensional vector quantities. **We want to prove to ourselves empirically that vectors add in a manner quite different to that of scalars.** For a two-dimension vector of magnitude F that is directed at an angle θ to a reference line--for example the x axis--the magnitude of the component of the vector parallel to the reference line is

$$F_x = F_{\parallel} = F \cos \theta, \quad (2)$$

while the magnitude of the component of the vector perpendicular to the reference line is

$$F_y = F_{\perp} = F \sin \theta, \quad (3)$$

as represented below in Figure Two. In general, a two-dimensional force vector can be written as

$$\vec{F} = F\hat{F} = \vec{F}_x + \vec{F}_y = F \cos \theta \hat{i} + F \sin \theta \hat{j}, \quad (4)$$

where θ is the total angle the vector makes to the positive branch of the x axis in the counterclockwise sense. Note the difference between the total angle θ and the reference angle θ_R .

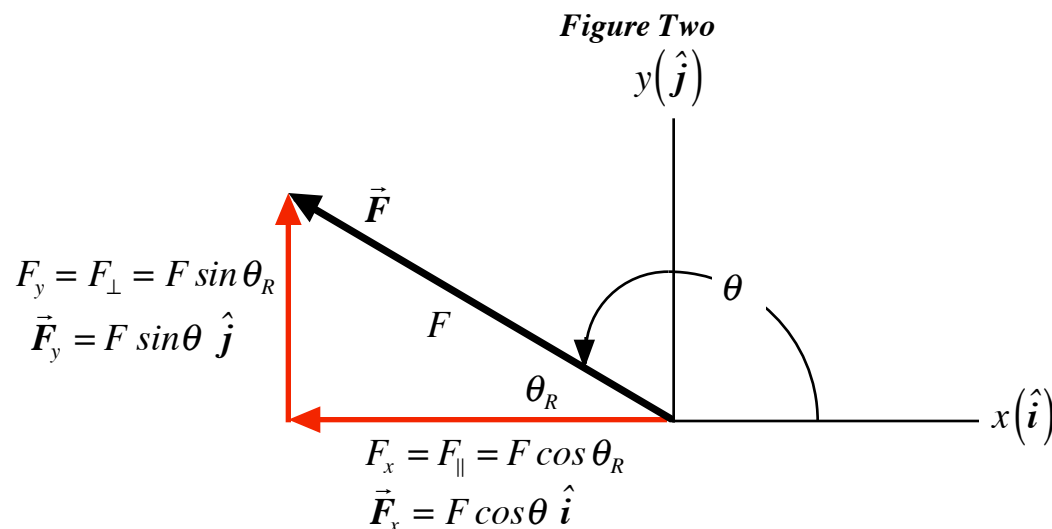

PHY2053 LABORATORY

Experiment Two

Addition and Resolution of Vectors

Name:

Date:

Day and Time:

EQUIPMENT NEEDED

Force Table

4 Pans Each of Mass 50 *gram* (I will use *gr* as the abbreviation for *gram* so that you do not confuse it with the *g* used for the acceleration due to gravity!)

4 Pulleys

Ring With Attached Threads

One Set of Slotted Masses

PROCEDURE

An Orientation

- 1.) Look carefully at the top of the force table--represented below in Figure Three. In the center is a small vertical post that can be removed. Around the rim is a circle divided into 360 *degrees*. We will use the degree scale on the rim to measure and signify the direction of the forces used in this experiment.
- 2.) Imagine a straight line segment running from the post through the 0° mark on the rim. Think of this as the positive branch of the *x*-axis of a Cartesian coordinate system. In a similar fashion, imagine a line segment running from the post through the 90° mark as the positive branch of the *y*-axis of the same Cartesian coordinate system. The positive *z*-axis would run vertically up the post.

Figure Three

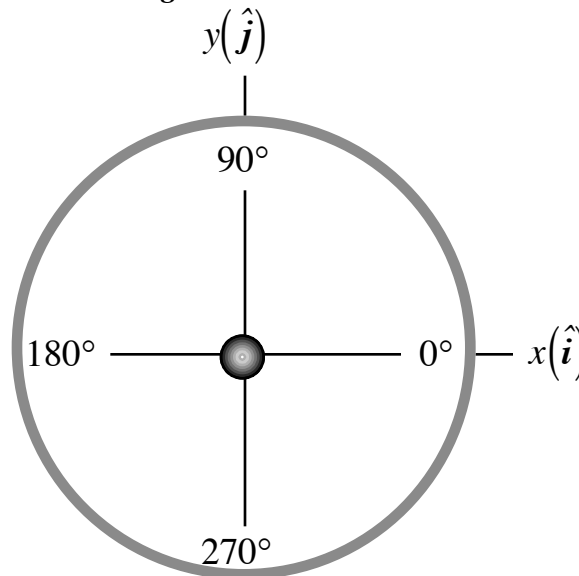

Components of a Single Force

- 3.) **Remove all weights that are attached to the threads!** Place the ring around the vertical post of the force table. Pull the threads out so that they are all flat on the top of the force table and not intertwined.
- 4.) Clamp a pulley onto the rim of the force table so that it is aligned with the 37° mark. Pull one of the threads over the channel of the pulley. Center the ring so that it is not in contact with the vertical post.
- 5.) Note that at the end of the thread there is a tied loop that can act as a stirrup. (If there is no such loop, tie one.) Take a 50 *gr* pan and place its hook end into the loop and let it hang

naturally. Now, place 150 *gr* onto the pan. (A **total mass** of 200 *gr* should be hanging from the string.)

6.) Note that the ring is now in **contact** with the center post. If you were to remove the post, what would happen to **the ring**?

If instead of removing the post, you were to cut the thread, what would **the pan and mass** do?

Force as a Vector

7.) We have a total mass of 200 *gram* hanging at the 37° mark. There are **two forces acting on the ring**. A “pulling” force is exerted on the ring by the thread, \vec{F}_{RT} . A “pushing” force is exerted on the ring by the post, \vec{F}_{RP} . Notice that these two forces act along the same **line of action**. These forces, and the line of action, are represented in Figure Four below.

Figure Four

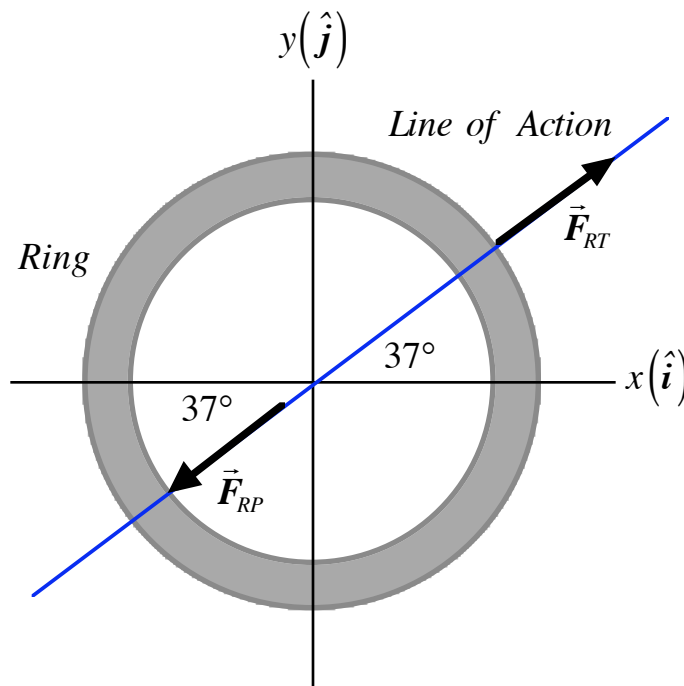

If we were to remove the post, the ring would **accelerate** in the direction of the pulling force \vec{F}_{RT} . We infer three important things:

- (1) A single force acting on a physical thing accelerates the physical thing.
- (2) A physical thing that is not accelerating must be subject to no forces or more than one force.
- (3) For a physical thing that is not accelerating, the sum of the forces acting on the physical thing must be zero. We signify this mathematically with

$$\sum \vec{F} = 0. \quad (5)$$

Using equation (5), we can write

$$\vec{F}_{RT} + \vec{F}_{RP} = 0, \quad (6)$$

and, therefore,

$$\vec{F}_{RT} = -\vec{F}_{RP}. \quad (7)$$

As forces are vector quantities, they have a magnitude and a direction and we can write equation (7) as

$$F_{RT} \hat{F}_{RT} = -F_{RP} \hat{F}_{RP}. \quad (8)$$

So,

$$F_{RT} = F_{RP}, \quad (9)$$

and

$$\hat{F}_{RT} = -\hat{F}_{RP}. \quad (10)$$

The force exerted on the ring by the post prevents the ring from accelerating and is said to **equilibrate** the ring. A physical thing that is not accelerating is in **translational equilibrium**.
8.) Now, we can verify whether or not our analysis of the force exerted on the ring by the post is correct. Secure a second pulley at the 217° mark of the force table. Hang a **total mass** of 200 gr to a second thread that passes over the second pulley. Under the influence of these two weights, the ring should be in equilibrium and no longer in contact with the post. You should be able to pull out the post without changing in any way the motion of the ring.

Components of a Force

9.) Let us now look at the components of the force exerted on the ring by the weight hanging at the 37° mark. The component of this force that is parallel to the x -axis is given by

$$\vec{F}_x = (.200 \text{ kg})(\cos 37^\circ) g \hat{i} = (.160 \text{ kg}) g \hat{i}, \quad (11)$$

while the component of this force parallel to the y -axis is given by

$$\vec{F}_y = (.200 \text{ kg})(\sin 37^\circ) g \hat{j} = (.120 \text{ kg}) g \hat{j}, \quad (12)$$

as represented in the Figure Five below.

Figure Five

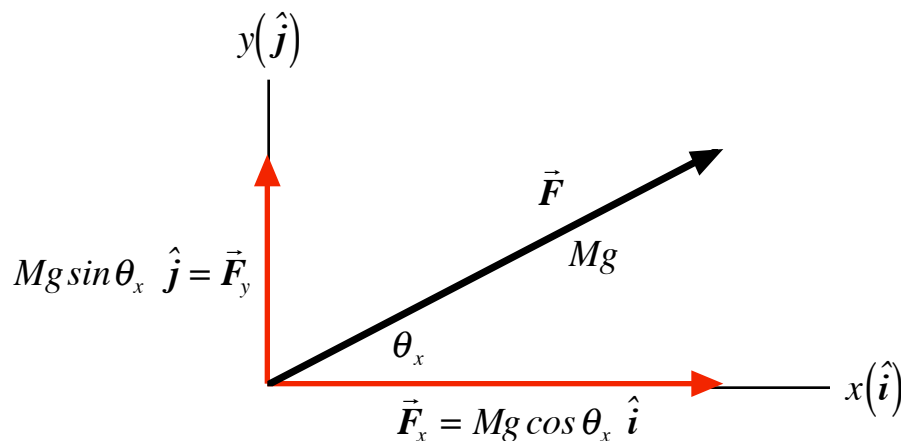

Our analysis suggests that a hanging weight with a total mass 160 gr placed at the 0°

mark and another hanging weight of total mass 120 gr placed at the 90° mark is **physically equivalent** to a single hanging weight with a total mass 200 gr placed at the 37° mark. This equivalence is represented graphically in Figure Six below.

Figure Six

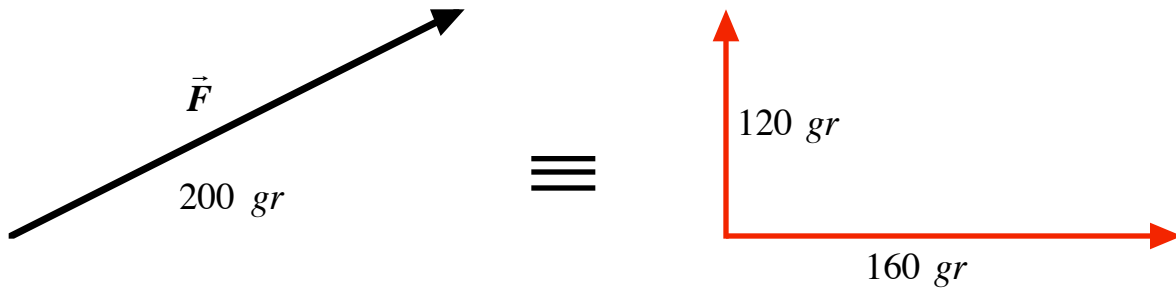

We now want to experimentally verify the results of our analysis. Leave in place the weight at the 217° mark. Make sure the post is in place. **Remove the weight at the 37° mark.** (The post now must exert a force on the ring!) Hang a **total mass** of 160 gr from a pulley secured at the 0° mark. Also, hang a **total mass** of 120 gr from a pulley secured at the 90° mark. When you have finished doing this, check the ring. It should no longer be in contact with the post. Physically, we should have the ring in equilibrium and you should be able to remove the post without changing the motion of the ring in any way. Physically, this means that a mass of 200 gr directed at 37° has exactly the same influence on the ring as two masses; one mass of 160 gr directed at 0° and a second mass of 120 gr directed at 90°. This illustrates the most important complicating factor of vectors: **vectors do not add like scalars**, that is, $200 \neq 160 + 120$. Instead, vectors add like the Pythagorean theorem, namely,

$$200 \equiv \sqrt{(160)^2 + (120)^2} .$$

Components for Two Forces

10.) **Clear the force table of all hanging masses.** Once the table is clear, hang a **total mass** of 300 gr at the 20° mark, and hang a **total mass** of 350 gr at the 60° mark. Verify the following:

$$(300 \text{ gr})(\cos 20^\circ) + (350 \text{ gr})(\cos 60^\circ) = 457 \text{ gr} .$$

$$(300 \text{ gr})(\sin 20^\circ) + (350 \text{ gr})(\sin 60^\circ) = 406 \text{ gr} .$$

This suggests that these two weights exert a net force of equivalent mass magnitude given by

$$M_{tot} = \sqrt{(457 \text{ gr})^2 + (406 \text{ gr})^2} = 611 \text{ gr} ,$$

directed at

$$\theta_{tot} = \tan^{-1} \left[\frac{406}{457} \right] = 41.6^\circ .$$

If this analysis is correct, then we should be able to equilibrate these two weights with
HI 2-4

611 gr directed at 221.6° . Place this mass at the calculated direction and see if the weights are equilibrated.

A Second Two Force Example

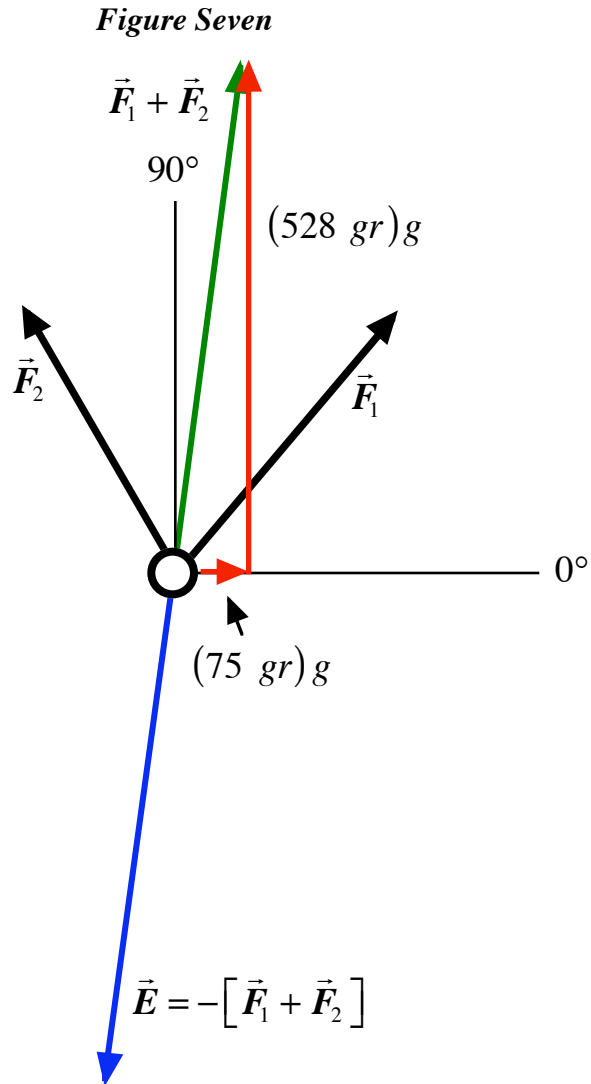

11.) Again, **clear the force table of all hanging masses**. Once the table is clear, hang a **total mass** of 350 gr at the 50° mark and a total mass of 300 gr at the 120° mark. Verify the following calculations:

$$(350 \text{ gr})(\cos 50^\circ) + (300 \text{ gr})(\cos 120^\circ) = 75 \text{ gr} .$$

$$(350 \text{ gr})(\sin 50^\circ) + (300 \text{ gr})(\sin 120^\circ) = 528 \text{ gr} .$$

So, we have a total mass equivalent of magnitude

$$M_{tot} = \sqrt{(75 \text{ gr})^2 + (528 \text{ gr})^2} = 533 \text{ gr} ,$$

directed at

$$\theta_{tot} = \tan^{-1} [528 / 75] = 81.9^\circ .$$

So, we should be able to equilibrate with 533 gr directed at 261.9°. Place this mass on the table at the specified angle and see if your two original masses are equilibrated. This physical state of affairs is represented above in Figure Seven.

An Example with Three Forces

Figure Eight

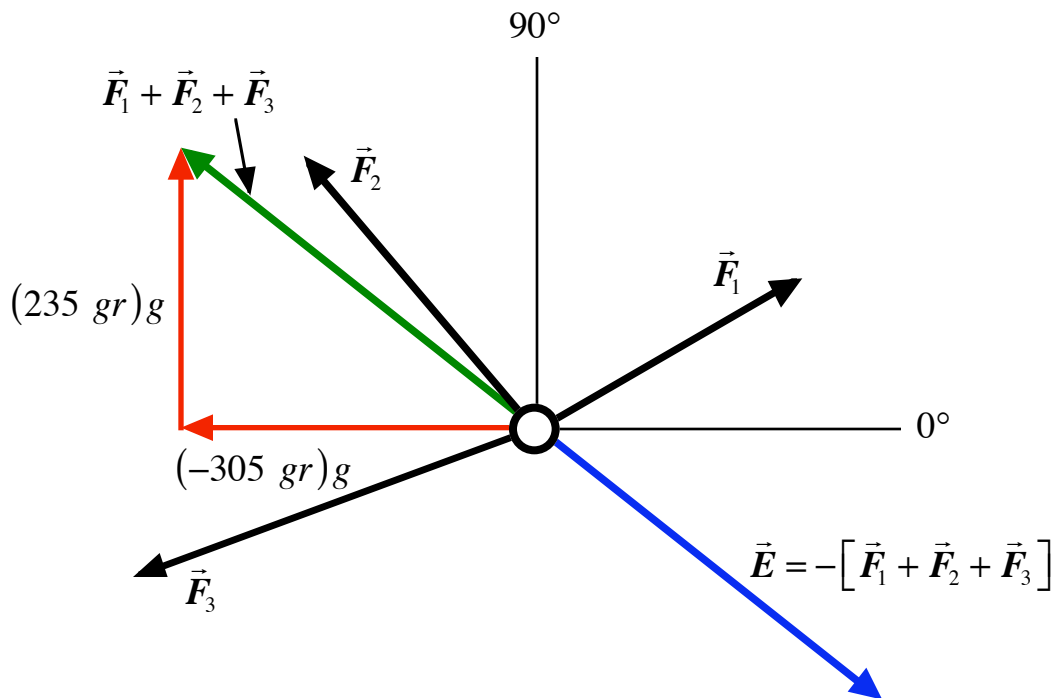

12.) Once again, **clear the force table of all hanging masses**. Once the table is clear, hang a **total mass** of 250 gr at the 30° mark, a **total mass** of 300 gr at the 130°, and a **total mass** of 350 gr at the 200° mark. Please verify the following calculations yourself:

$$(250 \text{ gr})(\cos 30^\circ) + (300 \text{ gr})(\cos 130^\circ) + (350 \text{ gr})(\cos 200^\circ) = -305 \text{ gr} .$$

$$(250 \text{ gr})(\sin 30^\circ) + (300 \text{ gr})(\sin 130^\circ) + (350 \text{ gr})(\sin 200^\circ) = 235 \text{ gr} .$$

This suggests a total mass equivalent of

$$M_{tot} = \sqrt{(-305 \text{ gr})^2 + (235 \text{ gr})^2} = 385 \text{ gr}$$

directed at
$$\theta_{tot} = 180 - \tan^{-1} \left[\frac{235}{305} \right] = 142.4^\circ .$$

This suggests that we should be able to equilibrate the three weights with 385 gr directed at the 322.4° mark. Put this weight on the table at the specified direction and see if you get equilibrium. This physical state of affairs is represented above in Figure Eight.

13.) Suppose that at some time t a point mass M is subjected to three forces given by

$$F_1 = 52 \text{ N at } \theta_1 = 45^\circ ,$$

$$F_2 = 73 \text{ N at } \theta_2 = 135^\circ ,$$

and

$$F_3 = 47 \text{ N at } \theta_3 = 205^\circ .$$

Calculate the magnitude and direction of the net force exerted on this point mass. Also, what would be the magnitude and direction of the equilibrating force?

$$F_{net} : \text{ _____ Newtons at _____ }^\circ ,$$

$$E : \text{ _____ Newtons at _____ }^\circ .$$

14.) When the sum of the forces acting on a physical thing is zero, we have a **necessary condition** for **static equilibrium**. A physical system cannot be in static equilibrium unless it is true that

$$\sum \vec{F} = 0 . \tag{13}$$

(In a later experiment, we will find out that equation (13) is **not sufficient** for determining static equilibrium. We must also concern ourselves with rotational motion.)

PHY2053 LABORATORY

Experiment Three

Projectile Motion

THEORY

On many occasions in the lecture, I have tossed objects around the room and I have dropped objects to the floor. These activities are examples of projectile motion. Projectile motion is motion where the only significant influence on the object is the Earth's gravitational force.

In our theoretical discussions of projectile motion, we make the following assumptions:

- 1) The initial speeds of the projectiles are small enough to ignore the curvature of the Earth, and to ignore the influence of air resistance.
- 2) Projectiles will be close enough to the surface of the Earth so that we can treat the accelerating influence of the Earth's gravitational force as a **constant**.

Since the projectile is subject to a constant acceleration--while in flight--we can use the kinematics equations of motion for constant acceleration that were derived in class. We have then, for constant acceleration, the co-ordinates of the position of the center of mass of the projectile given by:

$$x = x_o + v_{ox}t + \frac{1}{2}a_x t^2 \quad , \quad (1)$$

and

$$y = y_o + v_{oy}t + \frac{1}{2}a_y t^2 \quad . \quad (2)$$

The general equations for the components of the velocity are

$$v_x = v_{ox} + a_x t \quad , \quad (3)$$

and

$$v_y = v_{oy} + a_y t \quad . \quad (4)$$

Figure One
A Horizontal Launch off of a Table

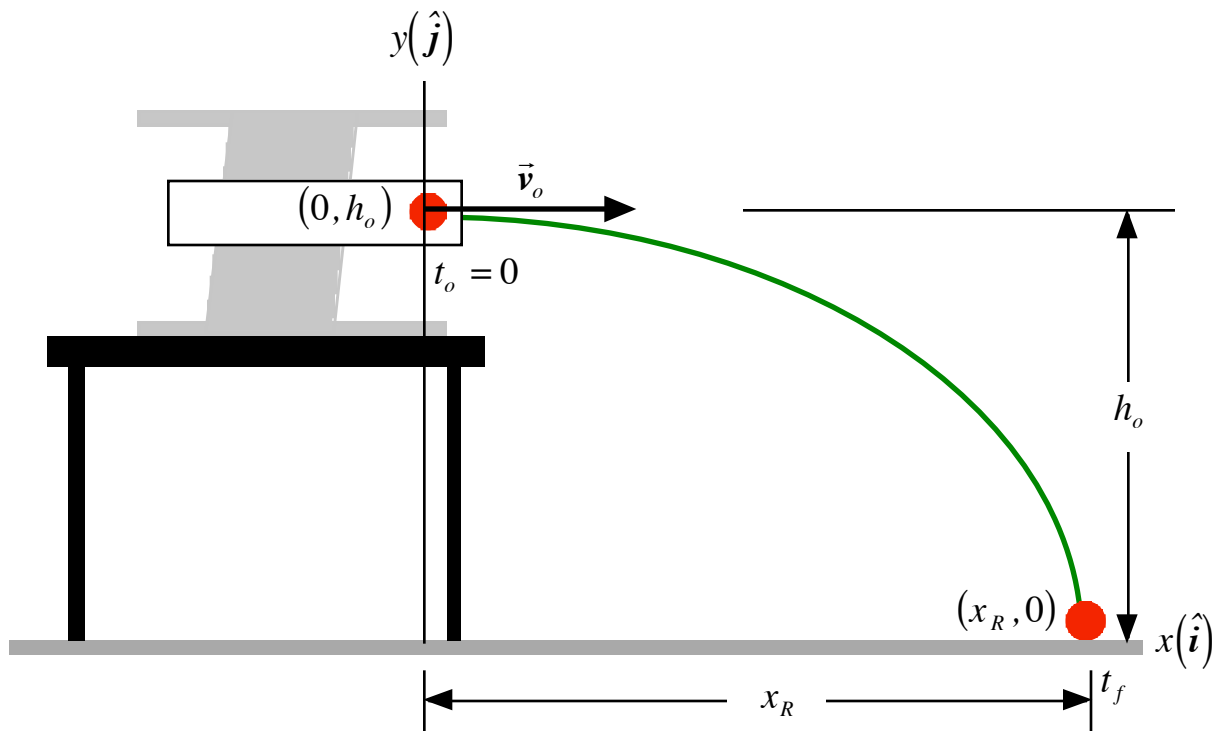

We are going to launch a projectile horizontally off of a table. By measuring the initial height of the projectile and how far it travels horizontally, we can determine the speed with which it was launched. In Figure One above, we have a representation of these physical states of affairs.

Using equation (1) we can write for time $t = t_f$:

$$x_R = v_o t_f . \quad (5)$$

Using equation (2) we can write for time $t = t_f$:

$$0 = h_o - \frac{1}{2} g t_f^2 , \quad (6)$$

and, therefore,

$$t_f = \sqrt{\frac{2h_o}{g}} . \quad (7)$$

Using equations (5) and (7), we can write

$$v_o = \frac{x_R}{t_f} = x_R \sqrt{\frac{g}{2h_o}} . \quad (8)$$

Next, we are going to launch the projectile off of the floor and see how the range value varies with the launch angle. We are going to assume that the launch speed is constant and equal to the value found in equation (8).

Assume that we have a Cartesian co-ordinate system as shown below in Figure Two. The projectile is launched at some initial time $t_o = 0$, from a point a distance $h_{o,F}$ above the origin of that Cartesian system with an initial speed of v_o at an angle θ_o with respect to the horizontal. At some later time t , the projectile is at some position P with coordinates x, y , which are defined by equations (1) and (2). (Please note that $h_{o,F}$ and x_R do not have the same value as in the launch off of the table, even though they represent the same kind of physical quantity.)

Figure Two
A Launch off of the Floor

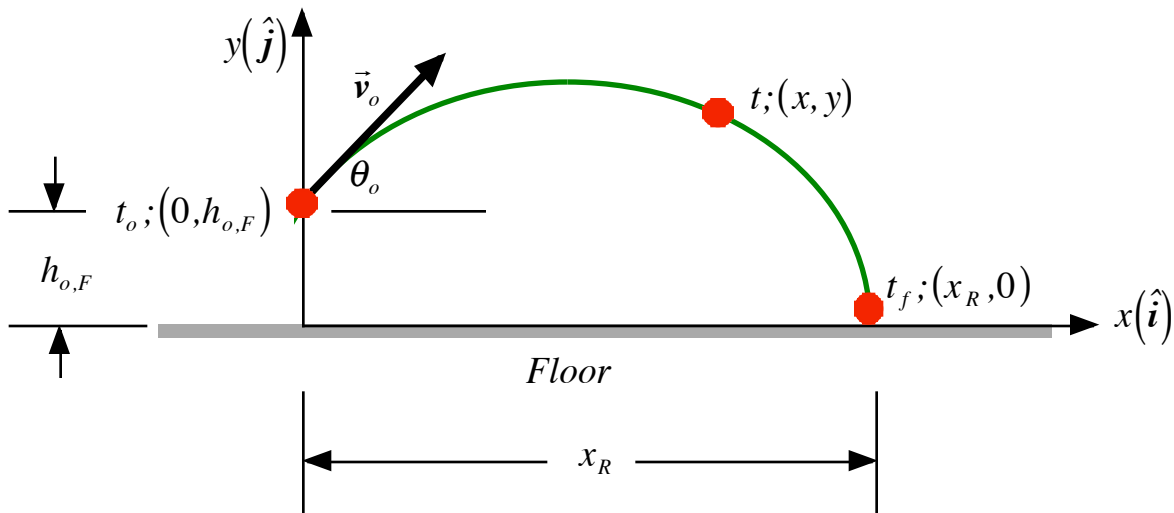

Using equation (1) we can write for time $t = t_f$:

$$x_R = (v_o \cos \theta_o) t_f . \quad (9)$$

Using equation (2) we can write for time $t = t_f$:

$$0 = h_{o,F} + (v_o \sin \theta_o) t_f - \frac{1}{2} g t_f^2 . \quad (10)$$

Rearranging terms we can write equation (10) as

$$\frac{1}{2} g t_f^2 - (v_o \sin \theta_o) t_f - h_{o,F} = 0 , \quad (11)$$

and

$$t_f^2 - \frac{2v_o \sin \theta_o}{g} t_f - \frac{2h_{o,F}}{g} = 0 . \quad (12)$$

Solving this quadratic equation, we find

$$t_f = \frac{v_o \sin \theta_o}{g} + \sqrt{\left(\frac{v_o \sin \theta_o}{g}\right)^2 + \left(\frac{2h_{o,F}}{g}\right)} . \quad (13)$$

Finally, then, we have

$$x_R = (v_o \cos \theta_o) t_f . \quad (14)$$

Our analysis of the predicted range value was calculated assuming that the launch speed was constant. The energy needed to move the projectile comes from the work done in compressing the spring. Using work-energy considerations, for a horizontal launch we can write

$$U_o^{sp} + K_o = U_L^{sp} + K_L , \quad (15)$$

where U_o^{sp} and U_L^{sp} are the elastic potential energy of the spring initially and later, respectively.

The kinetic energy of the projectile is, respectively, K_o and K_L . The initial conditions correspond to the instant when the process begins, and the later conditions correspond to the instant the projectile becomes a subject to the Earth's influence only. So, we would have for equation (15)

$$\frac{1}{2} k_{sp} x_c^2 + 0 = 0 + \frac{1}{2} M v_o^2 , \quad (16)$$

where k_{sp} is the spring constant and depends on the stiffness of the spring, x_c is the distance the spring is compressed initially, M is the mass of the projectile, and, of course, v_o is the launch speed of the projectile.

As we tilt the launcher, the gravitational force begins to have a component of force opposite the motion of the projectile and, therefore, would tend to slow down the projectile some. For non-horizontal launches, equation (15) must be modified to include the influence of the Earth's gravitational force. So, we have

$$U_o^{sp} + U_o^G + K_o = U_L^{sp} + U_L^G + K_L , \quad (17)$$

where U_o^G and U_L^G are the initial and later gravitational potential energy, respectively. So, in general, we can write

$$\frac{1}{2} k_{sp} x_c^2 + 0 + 0 = 0 + M g x_c \sin \theta_o + \frac{1}{2} M v_o'^2 . \quad (18)$$

Substituting equation (16) into equation (18) gives us

$$\frac{1}{2}Mv_o^2 + 0 + 0 = 0 + Mgx_c \sin \theta_o + \frac{1}{2}Mv_o'^2, \quad (19)$$

and, therefore,

$$v_o' = \sqrt{v_o^2 - 2gx_c \sin \theta_o}. \quad (20)$$

This suggests that a slightly better theoretical prediction for the range values would be

$$x_R' = (v_o' \cos \theta_o) t_f', \quad (21)$$

where t_f' is given by

$$t_f' = \frac{v_o' \sin \theta_o}{g} + \sqrt{\left(\frac{v_o' \sin \theta_o}{g}\right)^2 + \left(\frac{2h_{o,F}}{g}\right)}. \quad (22)$$

As you can see, equations like (13), (14), (21) and (22) are very complicated and would be quite tedious to do by hand. So, for this experiment, we are going to make use of a computer spreadsheet. Below, I show sample results from such a spreadsheet.

There is one more equation I wish to generate. The range value, in general, is given by

$$\begin{aligned} x_R &= (v_o \cos \theta_o) t_f = (v_o \cos \theta_o) \left[\frac{v_o \sin \theta_o}{g} + \sqrt{\left(\frac{v_o \sin \theta_o}{g}\right)^2 + \left(\frac{2h_{o,F}}{g}\right)} \right] \\ &= (v_o \cos \theta_o) \left[\frac{v_o \sin \theta_o}{g} + \sqrt{\frac{(v_o \sin \theta_o)^2 + 2h_{o,F}g}{g^2}} \right] \\ &= (v_o \cos \theta_o) \left[\frac{v_o \sin \theta_o + \sqrt{(v_o \sin \theta_o)^2 + 2h_{o,F}g}}{g} \right]. \end{aligned} \quad (23)$$

So, we can rearrange this as

$$\frac{x_R g}{v_o \cos \theta_o} = v_o \sin \theta_o + \sqrt{(v_o \sin \theta_o)^2 + 2gh_{o,F}}, \quad (24)$$

and then we have

$$\frac{x_R g}{v_o \cos \theta_o} - v_o \sin \theta_o = \sqrt{(v_o \sin \theta_o)^2 + 2gh_{o,F}}. \quad (25)$$

Squaring both sides gives us

$$\left[\frac{x_R g}{v_o \cos \theta_o} - v_o \sin \theta_o \right]^2 = (v_o \sin \theta_o)^2 + 2gh_{o,F}, \quad (26)$$

and

$$\frac{(x_R g)^2}{(v_o \cos \theta_o)^2} - 2x_R g \tan \theta_o = 2gh_{o,F}. \quad (27)$$

Simplifying,

$$\frac{(x_R g)^2}{(v_o \cos \theta_o)^2} = 2g(x_R \tan \theta_o + h_{o,F}), \quad (28)$$

Solving for the initial speed squared we find

$$\frac{x_R^2 g}{2(x_R \tan \theta_o + h_{o,F})(\cos \theta_o)^2} = v_o^2, \quad (29)$$

and

$$\begin{aligned} v_o &= x_R \sqrt{\frac{g}{x_R(2 \sin \theta_o \cos \theta_o) + 2h_{o,F}(\cos \theta_o)^2}} \\ &= x_R \sqrt{\frac{g}{x_R \sin 2\theta_o + 2h_{o,F}(\cos \theta_o)^2}}. \end{aligned} \quad (30)$$

As a check, note that when $\theta_o = 0$, this reduces to

$$v_o(\theta_o = 0) = x_R \sqrt{\frac{g}{2h_{o,F}}}, \quad (31)$$

as we found in equation (8).

PHY2053 LABORATORY

Experiment Three

Projectile Motion

Name:

Date:

Day and Time:

EQUIPMENT NEEDED

One Launcher
One One-Meter Stick
Clean Sheets of Paper
Masking Tape

One Projectile
One Two-Meter Stick
Carbon Paper
One Plunger

PROCEDURE

Please note that there is some inherent danger in this lab experiment. Your most important task is safety! Never launch a projectile until you are absolutely sure the range is clear. Do not cock the launcher until you are ready to launch. Do not stand in front of a cocked launcher. Never look into the barrel of a cocked launcher! Do not shoot yourself, your neighbor, the glass objects in the room, and, most importantly, do not shoot the instructor!

Part I: Measuring v_o --The Launch Speed of the Projectile

Figure Three

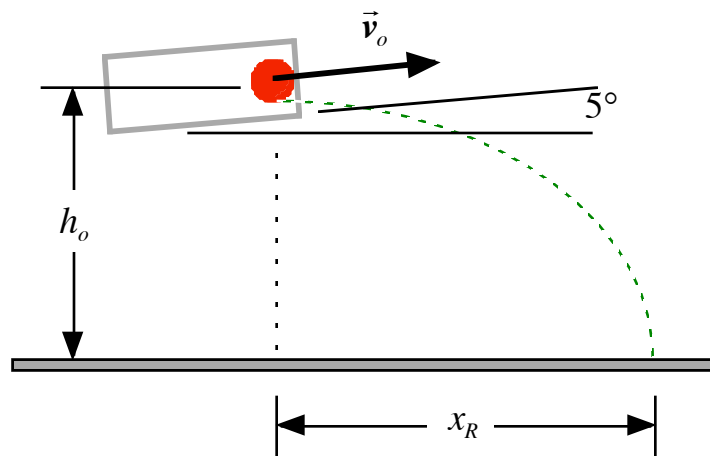

- 1.) **Place the launcher on your assigned lab table.** Point the launcher toward your group's assigned "alleyway." Using the hanging weight on the side of the launcher, make sure that the launcher is angled 5° to the horizontal.
- 2.) Locate **the point** on the barrel of the launcher where the projectile loses contact with the launching mechanism and becomes a projectile. Measure the vertical distance of this point above the floor, h_o , and record this value on the data sheet.
- 3.) **When the range is clear**, prepare the launcher to fire the projectile by using the plunger to push the steel ball all the way down the barrel of the launcher. This "cocks the gun." **If the range is still clear**, fire the gun and pay close attention to where the projectile strikes the floor. Tape carbon paper over a clean sheet of paper on the space where the ball strikes the floor.
- 4.) Without moving the launcher, fire the projectile again. (It is hoped that it strikes the paper!) Repeat this process for a total of **five times**. Measure the straight line horizontal distance from the launcher to the points where the projectiles struck the floor--the range x_R -- and record these values on the data sheet.

Part II: Measuring Range Values as a Function of the Launch Angle θ_o

Figure Four

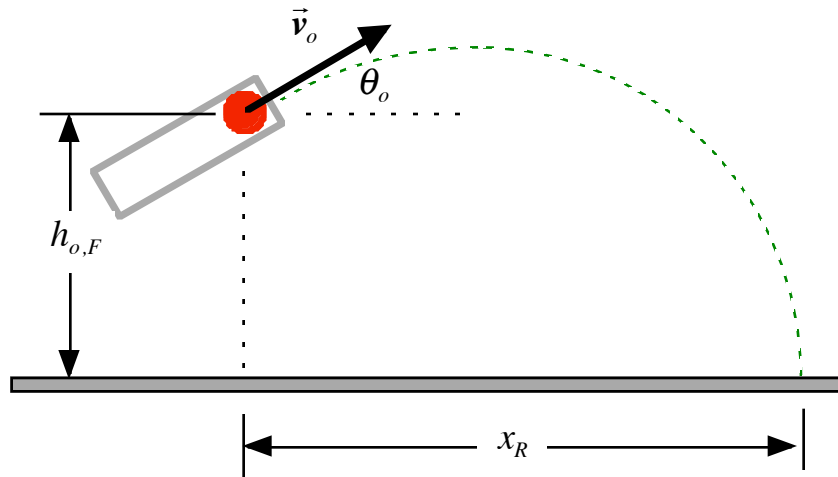

- 5.) **Place the launcher on the floor.** Point the launcher toward your assigned "alleyway."
- 6.) The launcher needs to **on the side** of the vertical face that **does not have the overhang**. Make sure the launcher is on this side and in the set of slots that will allow you to change the angle of the launch without changing the vertical height from which the ball is launched.
- 7.) Tilt the launcher so that it is inclined 5° to the horizontal. Next, measure the vertical height $h_{o,F}$, with respect to the floor, of the point on the barrel of the launcher where the projectile loses contact with the launching mechanism. Record this value on the data sheet. (**Note:** as we increase the tilt of the launcher, we want to keep this vertical distance the same! Use the moon shaped slot.)
- 8.) Load the launcher and, when it is safe to do so, fire the projectile making sure to carefully note where it strikes the floor. Fix a piece of paper over a piece of carbon paper on the spot noted. Fire the projectile **two times** from this angle. Measure the range value for each trial and record the value on the data sheet.
- 9.) Repeat step ten, making sure to keep $h_{o,F}$ constant, for the following angles:
 10° , 15° , 20° , 25° , 30° , 35° , 40° , 45° , 50° , 55° , 60° , 65° , 75° , 80° , and 85° .

Part III: Calculations

- 10.) If we assume the initial speed for the projectile is independent of the angle the launcher makes to the horizontal, then the speed of the projectile can be found using equation (30). We have

$$v_o = x_R \sqrt{\frac{g}{x_R \sin 2\theta_o + 2h_{o,F} (\cos \theta_o)^2}} \quad (32)$$

The expected time of flight and the expected range value for a specific launch angle, are given by equations (13) and (14). Recall,

$$t_f = \frac{v_o \sin \theta_o}{g} + \sqrt{\left(\frac{v_o \sin \theta_o}{g}\right)^2 + \left(\frac{2h_{o,F}}{g}\right)} \quad (33)$$

and

$$x_R = (v_o \cos \theta_o) t_f . \quad (34)$$

If we make a simple correction to the launch speed, the predicted range value is given by equation

$$x'_R = (v'_o \cos \theta_o) t'_f , \quad (35)$$

where

$$v'_o = \sqrt{v_o^2 - 2gx_c \sin \theta_o} . \quad (36)$$

and

$$t'_f = \frac{v'_o \sin \theta_o}{g} + \sqrt{\left(\frac{v'_o \sin \theta_o}{g}\right)^2 + \left(\frac{2h_{o,F}}{g}\right)} . \quad (37)$$

Any way you cut it, equations are a pain with which to do calculations.

No doubt the best way to do these calculations is to use a spreadsheet. Below, I have shown the results of some calculations--using phony data--that were made using the spreadsheet *Microsoft Excel*® . **See me about using a spreadsheet to do the calculations necessary for this lab!**

Sample Spreadsheet Calculations

#	h_o	g	v_o	θ_o	$\frac{v_o \sin \theta_o}{g}$	t_f
1	0.04 m	$9.80 \frac{m}{s^2}$	$3.20 \frac{m}{s}$	5°	0.028 s	0.118 s
2	0.04 m	$9.80 \frac{m}{s^2}$	$3.20 \frac{m}{s}$	10°	0.057 s	0.158 s
3	0.04 m	$9.80 \frac{m}{s^2}$	$3.20 \frac{m}{s}$	15°	0.085 s	0.204 s
4	0.04 m	$9.80 \frac{m}{s^2}$	$3.20 \frac{m}{s}$	20°	0.112 s	0.252 s
5	0.04 m	$9.80 \frac{m}{s^2}$	$3.20 \frac{m}{s}$	25°	0.138 s	0.300 s

<i>Expected x_R</i>	$x_{R,1}$	$x_{R,2}$	<i>Ave x_R</i>	<i>% Difference</i>
0.375 m	0.475 m	0.425 m	0.450 m	18.2
0.499 m	0.599 m	0.549 m	0.574 m	14.0
0.631 m	0.731 m	0.681 m	0.706 m	11.2
0.757 m	0.857 m	0.807 m	0.832 m	9.4
0.870 m	0.970 m	0.920 m	0.945 m	8.3

Data Sheet

Measuring the Projectile's Initial Speed;

$$\theta_o = \underline{\hspace{2cm}} \text{ }^\circ$$

$$h_o = \underline{\hspace{2cm}} \text{ } m$$

$$x_c = 0.080 \text{ } m$$

Range Values:

$$x_{R,1} = \underline{\hspace{2cm}} \text{ } m$$

$$x_{R,2} = \underline{\hspace{2cm}} \text{ } m$$

$$x_{R,3} = \underline{\hspace{2cm}} \text{ } m$$

$$x_{R,4} = \underline{\hspace{2cm}} \text{ } m$$

$$x_{R,5} = \underline{\hspace{2cm}} \text{ } m$$

**Measuring the Projectile's Range as a Function of Launch Angle;
Launch Off of the Floor:**

$$h_{o,F} = \text{_____} m$$

θ_o	$x_{R,1}$	$x_{R,2}$
5°		
10°		
15°		
20°		
25°		
30°		
35°		
40°		
45°		
50°		
55°		
60°		
65°		
70°		
75°		
80°		
85°		

PHY2053 LABORATORY

Experiment Four

Constant Acceleration

THEORY

The average acceleration is defined by

$$\vec{a}_{ave} = a_{ave} \hat{a}_{ave} = \frac{\Delta \vec{v}}{\Delta t} \quad , \quad (1)$$

and the instantaneous acceleration by

$$\vec{a} = a \hat{a} = \lim_{\Delta t \rightarrow 0} \frac{\Delta \vec{v}}{\Delta t} = \frac{d\vec{v}}{dt} \quad . \quad (2)$$

If the instantaneous acceleration is constant--no change in its magnitude a or its direction \hat{a} --then the average acceleration and the instantaneous acceleration are equal, and we can write

$$\vec{a}_{ave} = \vec{a} = \frac{\Delta \vec{v}}{\Delta t} \quad . \quad (3)$$

We can rearrange equation (3) and get

$$\Delta \vec{v} = \vec{a} \Delta t = \vec{v}_L - \vec{v}_E \quad . \quad (4)$$

The average velocity is defined by

$$\vec{v}_{ave} = \frac{\Delta \vec{r}}{\Delta t} \quad . \quad (5)$$

However, the average velocity can also be obtained using

$$\vec{v}_{ave} = \frac{1}{2} [\vec{v}_L + \vec{v}_E] = \frac{\Delta \vec{r}}{\Delta t} \quad . \quad (6)$$

We can rewrite equation (6), to make it look more like equation (4) in the following clever manner:

$$\frac{1}{2} [\vec{v}_L + \vec{v}_E - 2\vec{v}_E] = \frac{1}{2} [\vec{v}_L + \vec{v}_E] - \vec{v}_E = \frac{1}{2} [\vec{v}_L - \vec{v}_E] = \frac{1}{2} \vec{a} \Delta t = \frac{\Delta \vec{r}}{\Delta t} - \vec{v}_E \quad . \quad (7)$$

Equation (7) reduces to

$$\frac{\Delta \vec{r}}{\Delta t} - \vec{v}_E = \frac{1}{2} \vec{a} (\Delta t) \quad , \quad (8)$$

and gives us

$$\Delta \vec{r} = \vec{v}_E (\Delta t) + \frac{1}{2} \vec{a} (\Delta t)^2 \quad . \quad (9)$$

Equations (4) and (9) are the equations of motion of the center of mass of a physical thing which is subjected to a constant acceleration.

Today we are going to use a carrier on an air track to measure the acceleration of the carrier due to the influence of the Earth's gravitational force. Since the carrier will be traveling over such a short vertical distance, we can safely assume that the gravitational influence of the Earth on the carrier is **constant**, and, therefore, that the motion of the carrier can be described by equations (4) and (9).

We are going to release **from rest** a carrier of mass M on an air track inclined at an angle θ to the horizontal, as represented in Figure One below. As the carrier moves along the air track, the only forces acting on it are a normal force \mathcal{N} and the weight of the carrier itself, Mg . The carrier accelerates along the incline in the direction that I have labeled as the x -direction. The only force acting on the carrier in the x -direction is the x -component of the weight. It is this force that accelerates the carrier along the incline. Parallel to the x -axis we have

$$Ma_x = Mg \sin \theta \quad , \quad (10)$$

and the acceleration of the carrier along the air track is given by

$$a_x = g \sin \theta . \quad (11)$$

Figure One

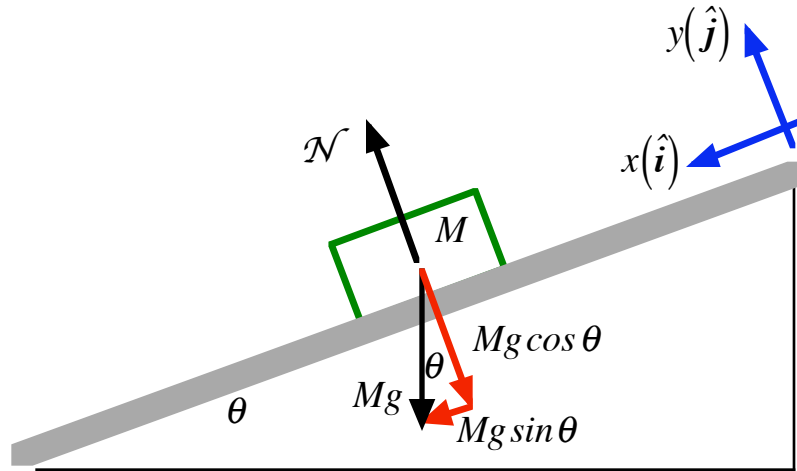

So, for one dimensional motion along the x -axis under the influence of a constant acceleration given by equation (11), the equations of motion become

$$v_x = v_{x,o} + (g \sin \theta) t , \quad (12)$$

$$x = x_o + v_{x,o} t + \frac{1}{2} (g \sin \theta) t^2 . \quad (13)$$

Consider the following scenario, as represented below in Figure Two. A carrier is released from rest at the origin of a Cartesian coordinate system the x -axis of which lies along the incline. The initial time value is zero. At time $t = t_1$, the carrier is at a position the x coordinate of which is $x = x_1$ and the instantaneous speed of which is $v_x = v_1$. At a still later time t_L , the carrier is at x_L and its instantaneous speed is v_L .

We can use equation (12) to find v_1 . We have for the instantaneous speed, as the carrier was released from rest,

$$v_1 = (g \sin \theta) t_1 . \quad (14)$$

Inspection of the diagram below should convince you that $x_L - x_1 = x_2$. I am going to call t_2 the time interval over which the carrier moves this distance x_2 . Note that the carrier has an instantaneous speed v_1 when it begins moving over the interval x_2 . So, using equation (13), we can write

$$x_L - x_1 = x_2 = v_1 t_2 + \frac{1}{2} (g \sin \theta) t_2^2 . \quad (15)$$

Using equation (14), we can rewrite equation (15) as

$$x_2 = [(g \sin \theta) t_1] t_2 + \frac{1}{2} (g \sin \theta) t_2^2 . \quad (16)$$

Rearranging the terms of equation (16) gives us

$$x_2 = (g \sin \theta) t_2 \left[t_1 + \frac{1}{2} t_2 \right] = \frac{(g \sin \theta) t_2}{2} [2t_1 + t_2]. \quad (17)$$

Solving equation (17) for g gives us our measured value for g :

$$g_{measured} = \frac{2x_2}{t_2 (2t_1 + t_2) (\sin \theta)}. \quad (18)$$

Figure Two

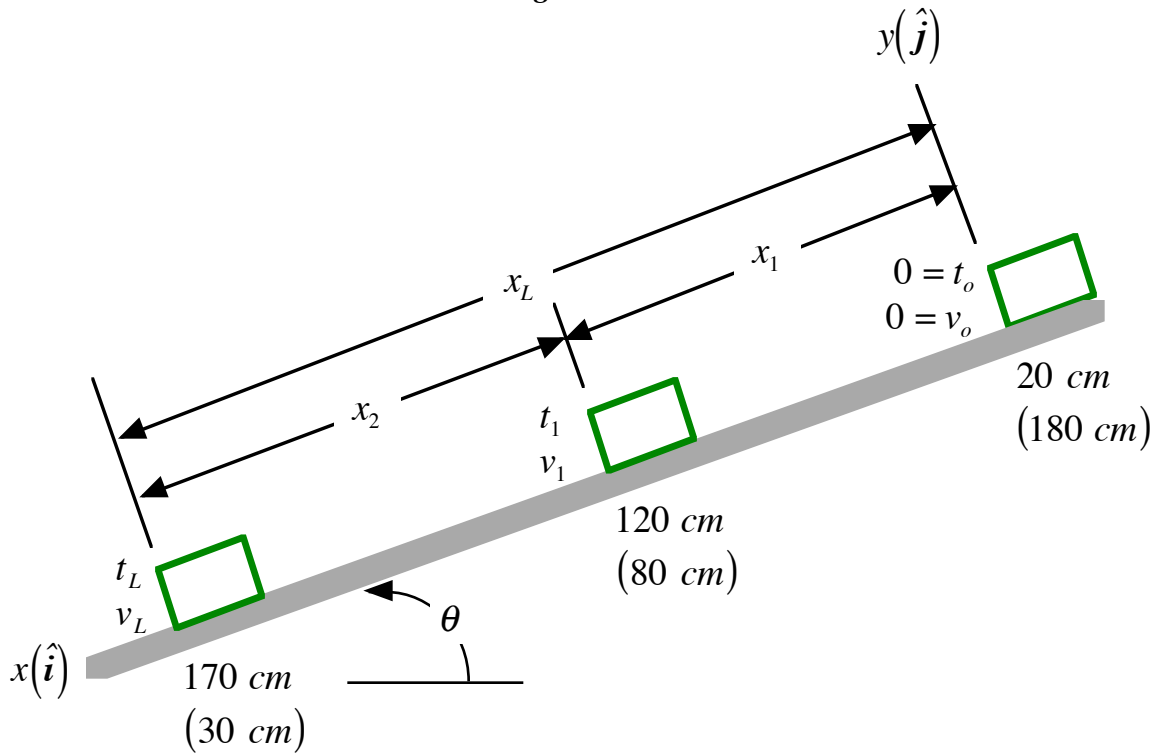

PHY2053 LABORATORY

Experiment Four

Constant Acceleration

Name:

Date:

Day and Time:

EQUIPMENT NEEDED

1 Air Track
1 Carrier
1 Photo-gate Without Timer
1 Digital Vernier
One 500 *gram* Slotted Mass

1 Air Pump
1 Photo-gate With Timer
1 Photo-gate Connector Cable
1 AC-Adapter For The Photo-gate

PROCEDURE

PLEASE:

Do not mark on or scratch the air track!
Carriers are never to be on the air track unless the air supply is on!
Also, please be careful not to tip the track over!

Leveling the Air Track

- 1.) Place the air track securely on the lab table; it should appear level. Connect the air supply hose to the track.
- 2.) Turn on the air supply and set the output level to 6 by turning the knob completely clockwise.
- 3.) Place a single carrier on the air track somewhere near the center of the track. If the carrier does not move, the track is level. If the carrier moves, then you must adjust the two footpads on the two-leg support until the carrier remains still when placed on the air track. (Turning the foot pads clockwise will raise the foot pads; counterclockwise will lower the foot pads.) Once the track is level, **remove the carrier** and turn off the air supply.

Inclining the Track

- 4.) Using the digital Vernier, measure the height h of a 500 *gram* slotted mass and record this value on the data sheet.
- 5.) Place the slotted mass under the one-leg support of the air track. You have now raised the single support leg by a distance of h . (See Figure Three below.)

Figure Three

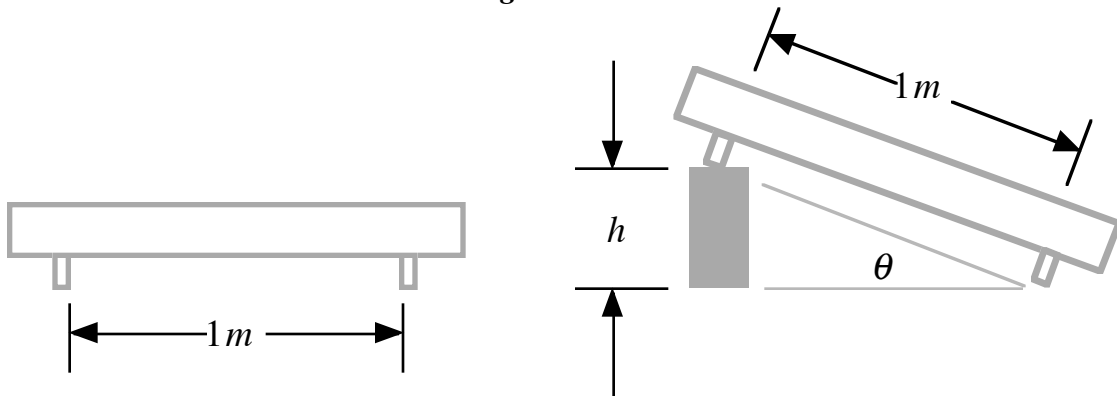

Inspection of the diagram above should convince you that

$$\sin\theta = \frac{h_{mm}}{1,000\text{ mm}} \equiv \frac{h_m}{1\text{ m}}, \quad (19)$$

where h_{mm} is measured in *millimeters*, (*mm*) or h_m is measured in *meters*. Calculate $\sin\theta$ and record this value on the data sheet.

Setting Up the Photo-gates

- 6.) First, familiarize yourself with the control switches on the photo-gate with the timer. There is a slide switch on the left-hand side of the control panel. Set that switch to **pulse mode**. Just to the right of this slide switch is a toggle switch. Set this toggle switch to on (that is the middle position). There is a slide switch at the upper right which controls the precision of the timer. Set this switch to 1 ms . (1 ms gives us a timing precision of one *millisecond* $\equiv 10^{-3}\text{ s} = 0.001\text{ s}$)
- 7.) Attach the AC-Adapter to the photo-gate with the timer and plug the adapter into an AC outlet.
- 8.) Connect the photo-gate with the timer to the photo-gate without a timer by using the connector cable provided.
- 9.) **Turn on the air supply** as previously set--should be set at 6.
- 10.) Depending on which side of the air track you are on, the raised end will be the 0 cm mark or the 200 cm mark. We are going to have the **photo-gate with timer** positioned so that it straddles the track at the 20 cm (180 cm) mark.
- 11.) Adjust the gate so that the carrier can pass through the gate with out hitting the gate and yet still trips the infrared signal that passes across the bottom of the gate through the pin holes. In Figure Four I have tried to show you how to line up the front of the carrier to the gate.

Figure Four

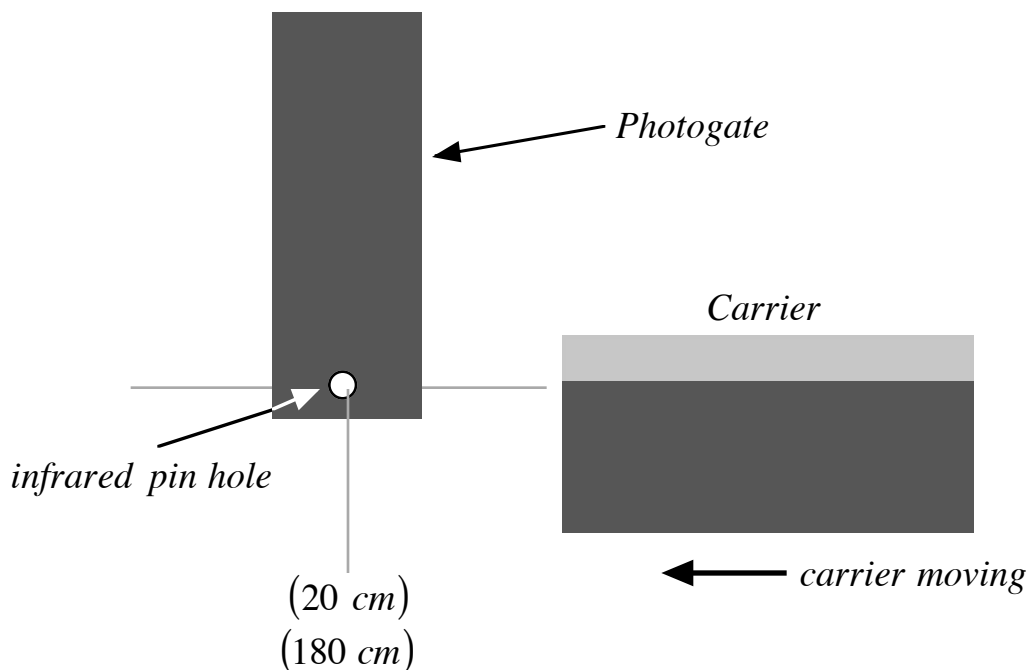

- 12.) If you use your hand to slowly move the carrier so that its front end passes the gate, a red light should go on. If you now back the carrier up and out of the gate, the red light should go off. You can use this process to precisely set the gate so that it lights up when the **front of the carrier** is at the 20 cm (180 cm) mark. (There should be **no thin vertical fin on the top**.)
- 13.) In a similar fashion, set up the other photo-gate, as precisely as possible, at the 120 cm (80 cm) mark.

Measuring the Time Interval t_1

- 14.) If the photo-gates have been set up properly, then, in pulse mode, the gates should measure the time interval for the carrier to travel from the first gate to the second gate. Let us test the timing.
- 15.) Reset the timer so that zeroes appear on the display.
- 16.) Move the carrier as close to the 20 cm (180 cm) mark as possible without tripping the timer. **Release the carrier from rest.** After it slides through the second gate, the timer should stop and the time interval should show on the display. **Do Not Let The Carrier Rebound Back Through The Gate!** Do this a couple of times to convince yourself that the numbers displayed are reasonable (try counting one thousand one, one thousand two, ...).
- 17.) When the gates are working properly, take **ten** separate measurements of t_1 , and record your values on the data sheet.

Measuring the Time Interval t_2

- 18.) With the track still inclined on the 500 gram mass, readjust the two photo-gates. Put the gate with the timer at the 120 cm (80 cm) mark. Place the second gate at the 170 cm (30 cm) mark. **Note that this makes** $x_2 = 0.500\text{ m}$.
- 19.) Again, move the carrier as close to the 20 cm (180 cm) mark as possible and **release the carrier from rest.** Take **ten** separate measurements for t_2 , record your values on the data sheet.
- 20.) Take the carrier off of the track. Turn off the air supply and make sure the track is level and securely sitting on the table.

Things to Do:

- 1.) Calculate and record the **average values** for t_1 and t_2 . Calculate a value for $g_{measured}$ and record it on the data sheet. Recall that

$$g_{measured} = \frac{2x_2}{\bar{t}_2(2\bar{t}_1 + \bar{t}_2)(\sin\theta)} . \quad (20)$$

- 2.) Calculate the per cent error between your measured value of g and the accepted value.

Recall: $g_{accepted} = 9.789\text{ m/s}^2$, and

$$\% \text{ Error} \equiv \left| \frac{g_{measured} - g_{accepted}}{g_{accepted}} \right| \times 100\% . \quad (21)$$

- 3.) I want you to spend some time on the experimental error. It is desirable to determine if $g_{accepted}$ falls within the interval $g_{measured} - 2e_g < g_{accepted} < g_{measured} + 2e_g$. To that end, we are going to use the least count values and, when we have them, standard deviation values to estimate the error, e_g . In our measurement of distances, the least count is $x_{2,LC} = 0.001\text{ m}$ and $h_{LC} = 0.001\text{ m}$. For each time value we will use the standard deviation for a small sample. So, we use σ_{s,t_1} and σ_{s,t_2} .

A reasonable estimate of the largest expected value for $g_{measured}$ would be given by:

$$g_{measured,max} = \frac{2(x_2 + x_{2,LC})}{(\bar{t}_2 - \sigma_{s,t_2})[2(\bar{t}_1 - \sigma_{s,t_1}) + (\bar{t}_2 - \sigma_{s,t_2})]}(h - h_{LC}) \quad (22)$$

A reasonable estimate of the error would be

$$e_g = |g_{measured,max} - g_{measured}| \quad (23)$$

This is the information you will need to calculate

$$g_{measured} - 2e_g < g_{accepted} < g_{measured} + 2e_g \quad (24)$$

Be sure to record your values below on page HI 4-3.

Data Sheet

<i>Run Number</i>	t_1 (seconds)	$ d_{t_1,i} = \bar{t}_1 - t_{1,i} $	$ d_{t_1,i} ^2$
1			
2			
3			
4			
5			
6			
7			
8			
9			
10			

$$\bar{t}_1 = \text{_____} s$$

$$\sigma_{s,t_1} = \sqrt{\frac{1}{N-1} \sum_{i=1}^N |d_{t_1,i}|^2} = \text{_____} s$$

<i>Run Number</i>	t_2 (seconds)	$ d_{t_2,i} = \bar{t}_2 - t_{2,i} $	$ d_{t_2,i} ^2$
1			
2			
3			
4			
5			
6			
7			
8			
9			
10			

$$\bar{t}_2 = \text{_____} s$$

$$\sigma_{s,t_2} = \sqrt{\frac{1}{N-1} \sum_{i=1}^N |d_{t_2,i}|^2} = \text{_____} s$$

$$\sin\theta = \frac{h_m}{1.000 \text{ m}} = \underline{\hspace{2cm}}$$

$$g_{\text{accepted}} = 9.789 \text{ m / s}^2$$

$$g_{\text{measured}} = \frac{2x_2}{\bar{t}_2(2\bar{t}_1 + \bar{t}_2)\sin\theta} = \underline{\hspace{2cm}} \frac{\text{m}}{\text{s}^2}$$

$$\% \text{Error} \equiv \left| \frac{g_{\text{accepted}} - g_{\text{measured}}}{g_{\text{accepted}}} \right| \times 100\% = \underline{\hspace{2cm}}$$

In the space below, calculate an estimate of the error for your measurement of g using the data you obtained. We have:

$$g_{\text{measured,max}} = \frac{2(x_2 + 0.001 \text{ m})}{(\bar{t}_2 - \sigma_{s,2})[2(\bar{t}_1 - \sigma_{s,1}) + (\bar{t}_2 - \sigma_{s,2})]}(h - 0.001 \text{ m})$$

$$= \underline{\hspace{2cm}} \text{ m / s}^2, \quad (22)$$

For the estimate of the error, we have

$$e_g = |g_{\text{measured,max}} - g_{\text{measured}}|$$

$$= \underline{\hspace{2cm}} \text{ m / s}^2. \quad (23)$$

(Use only one significant digit in your final calculation of e_g .) Now, you can determine if

$$g_{\text{measured}} - 2\varepsilon_g < g_{\text{accepted}} < g_{\text{measured}} + 2\varepsilon_g. \quad (24)$$

PHY2053 LABORATORY

***A Quantitative Interlude:
A Mathematical Description of
Circular Motion***

THEORY

Circular motion is a fairly complicated affair. To help us in our analysis of circular motion, I am going to use a more appropriate coordinate system--a so-called cylindrical or polar coordinate system. First, consider a point mass M moving with instantaneous speed v in a counterclockwise sense on a circular path of radius R as represented below in Figure One.

Figure One

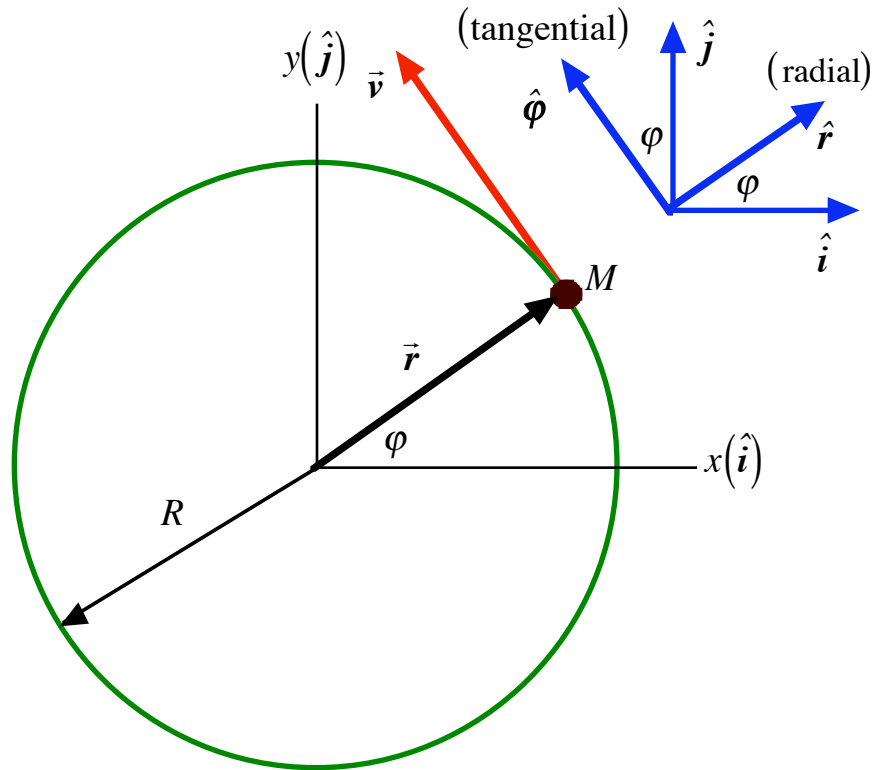

First, note that \hat{r} is a unit vector that points away from the center of the circle along a line that is called the radial line. It is the direction of the **instantaneous position vector**. For circular motion, the **instantaneous position** is given by

$$\vec{r} = R \hat{r} = R \cos \varphi \hat{i} + R \sin \varphi \hat{j} . \quad (1)$$

The unit vector $\hat{\phi}$ is pointed in a direction perpendicular to the radial line, in the direction of increasing φ , and is in the direction of the instantaneous velocity; we call this the tangential direction. For circular motion, we have

$$\vec{v} = v \hat{\phi} = v \left[-\sin \varphi \hat{i} + \cos \varphi \hat{j} \right] . \quad (2)$$

We use this notation because virtually everything we need for a complete description of circular motion is either parallel to the radial line or parallel to the tangential line.

Next, consider a point mass M moving on a circular path of radius R with **increasing speed** as represented in Figure Two below. Inspection of Figure Two, along with the definition of the average velocity, leads us to write

$$\begin{aligned}
\vec{v}_{ave} &= \frac{\Delta \vec{r}}{\Delta t} = \frac{1}{\Delta t} [\vec{r}_L - \vec{r}_E] \\
&= \frac{1}{\Delta t} \left[(R \cos \Delta \varphi \hat{i} + R \sin \Delta \varphi \hat{j}) - (R \hat{i}) \right] \\
&= \frac{R}{\Delta t} \left[(\cos \Delta \varphi - 1) \hat{i} + (\sin \Delta \varphi) \hat{j} \right] = \vec{v}_{ave} .
\end{aligned} \tag{3}$$

To find the instantaneous velocity, we need to find out what happens to equation (3) as $\Delta \varphi \rightarrow 0$.

Figure Two

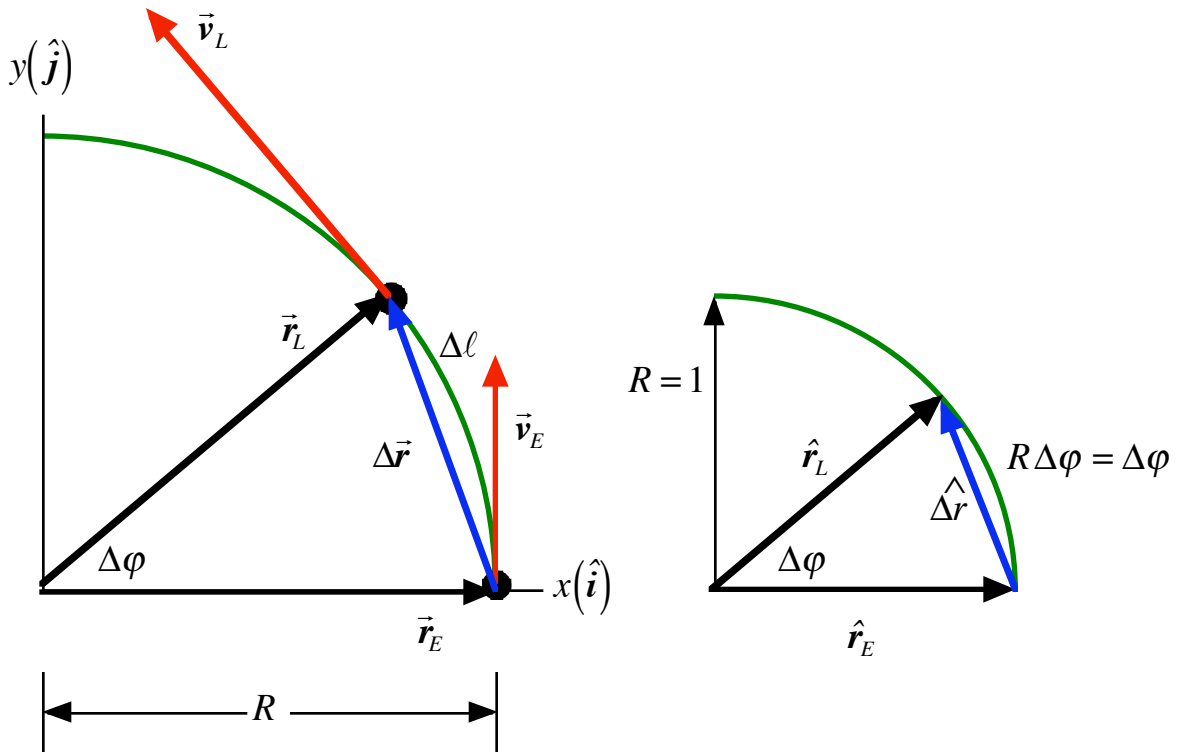

Next, recall that for small angles in **radian** measure

$$\text{as } \Delta \varphi \rightarrow 0 \text{ , then } \begin{cases} \cos \Delta \varphi \rightarrow 1 \\ \sin \Delta \varphi \rightarrow \Delta \varphi \end{cases} . \tag{4}$$

Using these relationships, equation (3) becomes

$$\vec{v} = \lim_{\Delta t \rightarrow 0} \frac{\Delta \vec{r}}{\Delta t} = R \left[\lim_{\Delta t \rightarrow 0} \frac{\Delta \varphi}{\Delta t} \right] \hat{j} = R \omega \hat{j} , \tag{5}$$

where we have defined a new quantity called the **instantaneous angular speed** , ω , by

$$\omega = \lim_{\Delta t \rightarrow 0} \frac{\Delta \varphi}{\Delta t} = \frac{d\varphi}{dt} . \tag{6}$$

(It is important to remember that the angular speed is always measured in *radians per second*. Since one revolution is equivalent to 2π radians, then we can write

$$1 \text{ rpm} \equiv \frac{2\pi \text{ radians}}{60 \text{ seconds}} = 0.10472 \frac{\text{rad}}{\text{s}} .) \text{ The direction of equation (5) is } \hat{j} \text{ and is telling us}$$

that as $\Delta t \rightarrow 0$, $\Delta\phi \rightarrow 0$, and that the unit vector $\hat{\Delta r}$ is in the same direction as the direction of the instantaneous earlier velocity, that is, $\hat{\Delta r} = \hat{v}_E$. So, we conclude that the velocity vector is perpendicular to the position vector--that is, **the velocity vector is always directed tangent to the circular path**-- and

$$\vec{v} = v \hat{v} = R \omega \hat{\phi} . \quad (7)$$

We now wish to determine what happens to the velocity. We see from Figure Three below that:

Figure Three

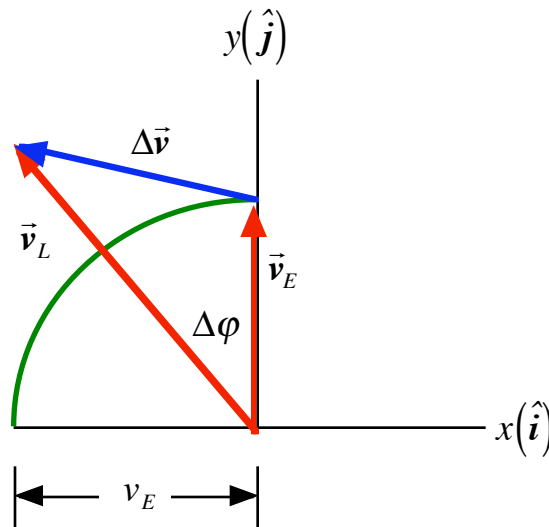

Using Figure Three above and the definition of the average acceleration, we can write

$$\begin{aligned} \vec{a}_{ave} &= a_{ave} \hat{a}_{ave} = \frac{\Delta \vec{v}}{\Delta t} = \frac{1}{\Delta t} [\vec{v}_L - \vec{v}_E] \\ &= \frac{1}{\Delta t} [(-v_L \sin \Delta\phi \hat{i} + v_L \cos \Delta\phi \hat{j}) - v_E \hat{j}] \\ &= \frac{1}{\Delta t} [(-v_L \sin \Delta\phi) \hat{i} + (v_L \cos \Delta\phi - v_E) \hat{j}] . \end{aligned} \quad (8)$$

Next, we are interested in what happens to equation (8) as $\Delta\phi \rightarrow 0$; this, of course will give us the instantaneous acceleration. Using equation (4), we have

$$\begin{aligned} \vec{a} = a \hat{a} &= \lim_{\Delta t \rightarrow 0} \frac{\Delta \vec{v}}{\Delta t} = -v \lim_{\Delta t \rightarrow 0} \frac{\Delta\phi}{\Delta t} \hat{i} + \lim_{\Delta t \rightarrow 0} \frac{\Delta v}{\Delta t} \hat{j} \\ &= -v \omega \hat{i} + a_{\perp to \hat{v}_E} \hat{j} . \end{aligned} \quad (9)$$

Equation (9) is telling us that in general, we could have two kinds of acceleration.

First, we have the $-\hat{i}$ component of acceleration. Note that in the limit as the time interval approaches zero, $-\hat{i}$ is in a direction opposite the direction of the earlier position, that is, it is directed toward the center of the circle and parallel to the radial line. So, we have

$$\vec{a}_{rad} = -v\omega \hat{r} = -\frac{v^2}{R} \hat{r} = -R\omega^2 \hat{r} , \quad (10)$$

where we have made use of equations (9) and (7). This acceleration is called the **radial acceleration** because it is directed parallel to the radial line. The $-\hat{r}$ tells us it is pointing **toward** the center of the circle. (Many physicists call this the **centripetal acceleration**. I am going to call it the radial acceleration.) The **radial acceleration** is responsible for the **change in direction** of the motion of the physical thing as it moves in a circle. You can not have circular motion without a radial acceleration directed toward the center of the circle with a magnitude

$$a_{rad} = \frac{v^2}{R} = R\omega^2 . \quad (11)$$

The other acceleration term is parallel to the instantaneous direction of motion and, therefore, is parallel to the tangential line. Hence, we call this acceleration the **tangential acceleration**. The tangential acceleration--since it is parallel to the instantaneous direction of motion--is what causes the object to change its speed. If the object is moving with constant speed, the tangential acceleration is zero. From equation (7) we know that the instantaneous speed is given by

$$v = R\omega . \quad (12)$$

So, if we were to change this--remembering that the radius of the circle is not changing--we would have

$$\Delta v = R \Delta\omega , \quad (13)$$

and then we could write

$$a_{ave,tan} = \frac{\Delta v}{\Delta t} = R \frac{\Delta\omega}{\Delta t} = R\alpha_{ave} , \quad (14)$$

where we have introduced the average angular acceleration α_{ave} , defined by

$$\alpha_{ave} = \frac{\Delta\omega}{\Delta t} = \frac{1}{\Delta t} [\omega_L - \omega_E] . \quad (15)$$

So, if do our limiting process, we can find the instantaneous values. We have

$$a_{tan} = R \left[\lim_{\Delta t \rightarrow 0} \frac{\Delta\omega}{\Delta t} \right] = R\alpha , \quad (16)$$

where we have introduced a new quantity called the **angular acceleration**, α , that is defined by

$$\alpha = \lim_{\Delta t \rightarrow 0} \frac{\Delta\omega}{\Delta t} = \frac{d\omega}{dt} . \quad (17)$$

The tangential component of acceleration, then, is given by

$$\vec{a}_{tan} = R\alpha \hat{\phi} , \quad (18)$$

In Summary

When a physical thing is moving on a circular path, most of the kinematic quantities of interest are parallel to a radial line or a tangential line. The position and the radial component of the acceleration are parallel to the radial line; the instantaneous velocity and the tangential acceleration are parallel to the tangential line. For this reason, the radial-tangential coordinate system is extremely useful for describing circular motion. In Figure Two below, I have represented these states of affairs for various kinds of circular motion.

In terms of the radial-tangential coordinate system, the position is given by

$$\vec{r} = r\hat{r} = R\hat{r} \quad , \quad (19)$$

while the instantaneous velocity is given by

$$\vec{v} = v\hat{\varphi} = R\omega\hat{\varphi} \quad . \quad (20)$$

As the object moves on the circular path, its instantaneous direction of motion must change. This change in direction is the result of an instantaneous radial acceleration given by

$$\vec{a}_{rad} = a_{rad}\hat{a}_{rad} = -\frac{v^2}{R}\hat{r} = -R\omega^2\hat{r} \quad . \quad (21)$$

where v is the instantaneous linear speed and ω is the instantaneous angular speed.

If the instantaneous speed of the object is changing, then this is the result of a tangential acceleration which is given by

$$\vec{a}_{tan} = a_{tan}\hat{a}_{tan} = R\alpha\hat{\varphi} \quad , \quad (22)$$

where we are assuming that α can be positive or negative depending on how the angular speed is changing, or, more precisely, whether φ is increasing or decreasing.

For a constant mass, Newton's second law when applied to circular motion becomes, in the radial direction,

$$\sum \vec{F}_{rad} = M\vec{a}_{rad} = -M\left[\frac{v^2}{R}\right]\hat{r} = -M[R\omega^2]\hat{r} \quad , \quad (23)$$

where the bracketed terms represent the radial acceleration expressed in terms of the translational speed and the angular speed, respectively. That is,

$$\vec{a}_{rad} = a_{rad}\hat{a}_{rad} = -\frac{v^2}{R}\hat{r} = -R\omega^2\hat{r} \quad . \quad (24)$$

In the tangential direction, Newton's second law becomes

$$\sum \vec{F}_{tan} = M\vec{a}_{tan} = M[R\alpha]\hat{\varphi} \quad , \quad (25)$$

where the tangential acceleration is given by

$$\vec{a}_{tan} = a_{tan}\hat{a}_{tan} = R\alpha\hat{\varphi} \quad . \quad (26)$$

Figure Two
Point Masses Moving On Circular Paths

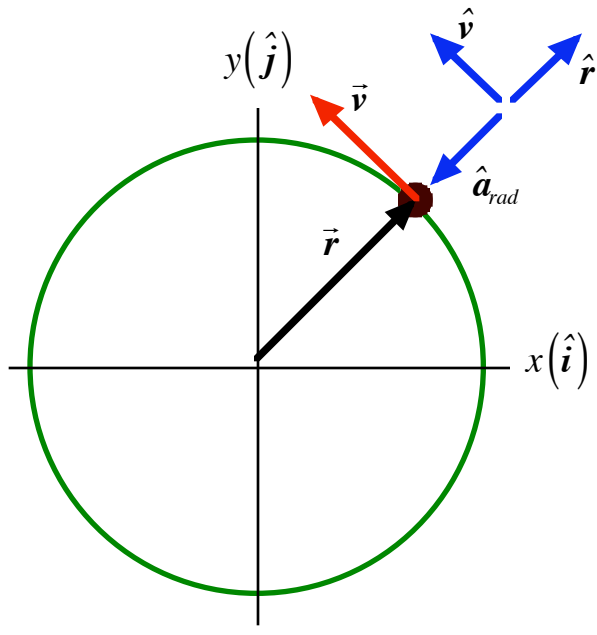

*speed constant
 counterclockwise*

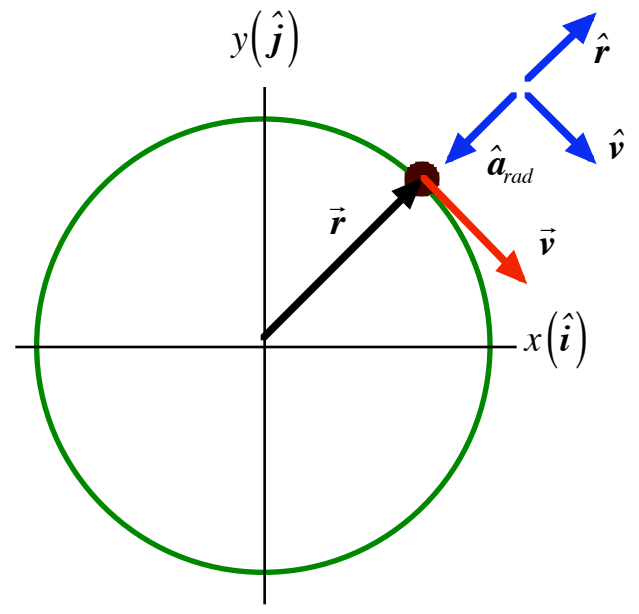

*speed constant
 clockwise*

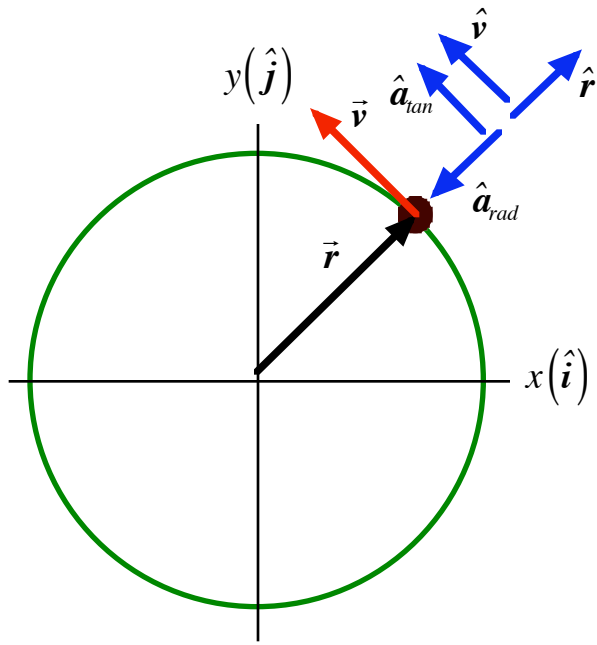

*speed increasing
 counterclockwise*

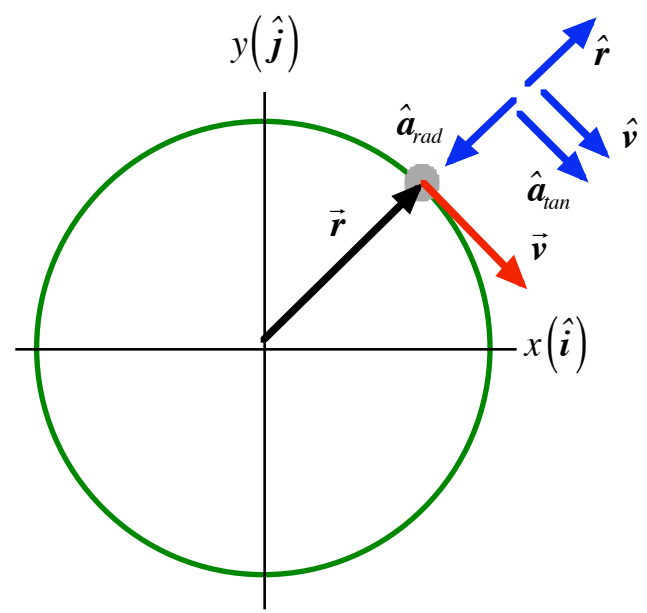

*speed increasing
 clockwise*

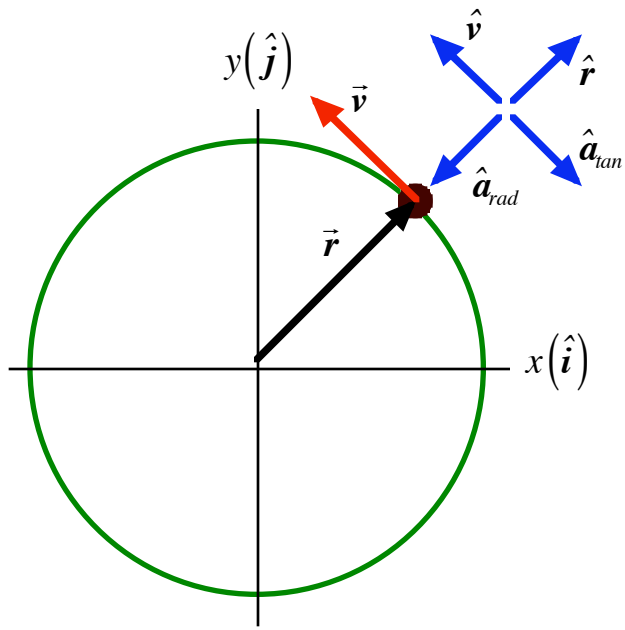

*speed decreasing
counterclockwise*

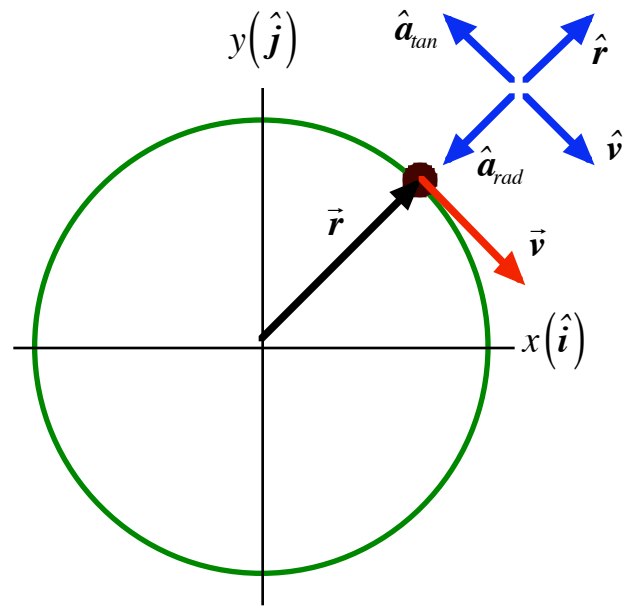

*speed decreasing
clockwise*

PHY2053 LABORATORY

Experiment Five

Circular Motion

THEORY

A cylindrical mass M is attached to one end of an elastic spring, as represented below in Figure One. The other end of the spring is attached to the cage within which the mass is housed. The shaft of the cage is secured in the chuck of a variable speed electric motor that is aligned vertically so that the cylindrical mass is free to move on a horizontal circular path. As we demonstrated in the quantitative interlude on circular motion, for an object to move on a circular path, there must be a net **radial force** exerted on the object of magnitude

$$F_{net,rad} = MR\omega^2 , \quad (1)$$

where R is the radius of the circular path and ω is the magnitude of the instantaneous angular velocity. This radial force is exerted on the cylindrical mass by the spring. The direction of this force is always toward the center of the circular path on which the cylindrical mass moves. That path is centered, of course, on the shaft about which the cylindrical mass rotates.

Inspection of the caged mass should convince you that as the mass rotates faster, it will move further away from the shaft about which it rotates. There is a rotation rate at which the cylindrical mass will bump into a needle pointer causing the pointer to rise up and point to the top of a screw located directly above the shaft. (In this experiment, we want to find the **minimum rpm** at which the mass must rotate to cause this needle to just barely move up. Note that if we continue to increase the rpm value the needle will remain up. However, then the spring and the needle will be exerting forces on the mass the sum of which must yield equation (1). That is why **we want the minimum rpm value.**)

When we have determined this minimal rpm value, we know that the tension in the spring must equal equation (1), that is

$$T_{rpm\ min} = MR\omega_{rpm\ min}^2 . \quad (2)$$

If we now take the caged mass out of the circular motion machine and set it up in a configuration like that represented below in Figure Two, we can **directly measure the tension** value in equation (2) by hanging additional mass to the cylinder until it causes the spring to extend into a position which just barely causes the pointer to rise. Here, we are attempting to find the **minimum total mass** necessary to get the pointer in the same configuration it was in when rotating at minimum rpm. In that case, we would have

$$T_{mass\ min} = (M + M_{min\ added})g , \quad (3)$$

where g has the value

$$g = 9.789\ m / s^2 . \quad (4)$$

Of course, the atoms of the spring do not know if they are up against the pointer because they are rotated or as the result of being stretched. So, we would expect

$$T_{rpm\ min} = T_{mass\ min} . \quad (5)$$

PHY2053 LABORATORY

Experiment Five

Circular Motion

Name:

Date:

Day and Time:

EQUIPMENT NEEDED

Circular Motion Machine
Caged Mass
Clamp
Level
Vise
50 gram Mass Pan

Goggles
One Set of Slotted Masses
Stand for Spring Scale
Digital Vernier
Short Aluminum Rod

PROCEDURE

- 1.) Place the shaft of the “**caged mass**” into the motor chuck. Make sure the caged mass remains level as you tighten the chuck with the **chuck-key** that is attached to the power cable of the circular motion machine. Set the tension of the spring to any value **less than ten**. (See Figure One below.)
- 2.) Put on your goggles. (**This is not optional! Goggles are to be worn whenever the “caged mass” is rotating!**)
- 3.) Turn on the machine and set it to RPM mode. Slowly increase the rotational speed until the pointer in the middle of the caged mass just barely rises and points to the top of the screw in the middle of the cage. Record this minimum *rpm* value on the data sheet and turn off the circular motion machine.
- 4.) Remove the caged mass from the circular motion machine.
- 5.) Set up the assembly that will be used to measure the spring force directly. (See Figure Two above.) Please make sure that all clamps are securely fastened. **We do not want the hanging masses to fall on any toes!**
- 6.) Add masses to the pan until you find the minimum amount of weight needed to stretch the spring a sufficient distance until the pointer in the middle of the caged mass just barely rises and points to the top of the screw in the middle. Record the **total mass** value found.
- 7.) While the spring is maximally stretched, use the digital Vernier to measure the radius of the circular path on which the small cylindrical mass moved. Record this value on the data sheet. (Measure from the axis of rotation to the center of mass of the cylindrical mass.)
- 8.) Calculate both F_{rad} and F_{dir} , and record the values on the data sheet for the tension **less than ten**.
- 9.) Calculate the percent difference between F_{rad} and F_{dir} and also record this on the data sheet for the tension **less than ten**.
- 10.) Repeat steps 1.) through 9.) with a spring tension setting of **greater than ten**.

Figure One
Machine Used to Measure the Radial Force Exerted by the Spring

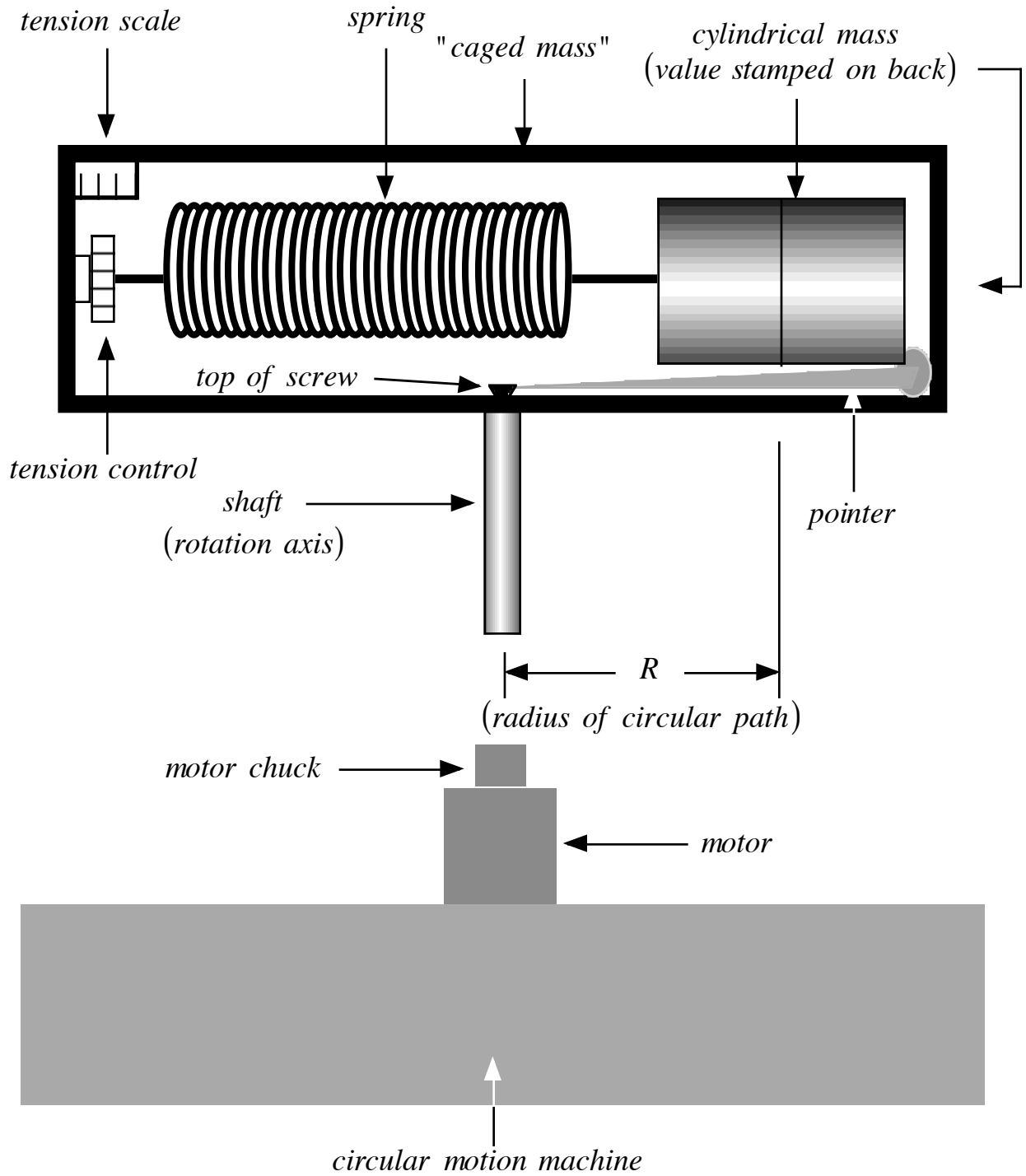
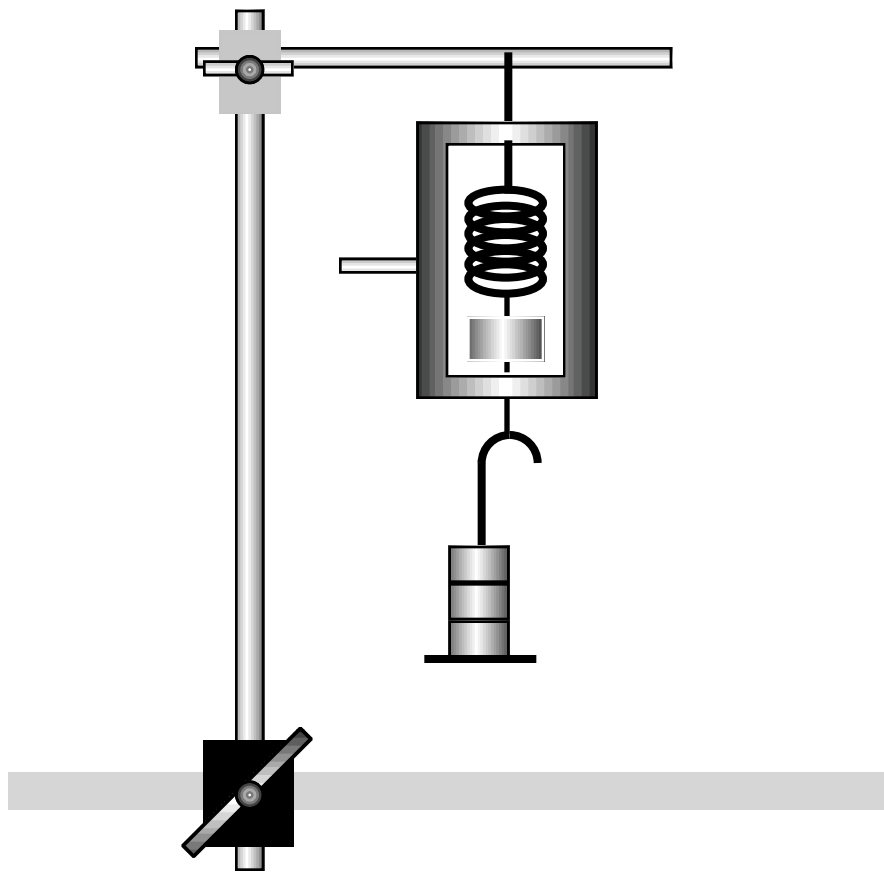

Figure Two
Method for the Direct Measure of the Spring Force



Data Sheet
Trial One (Spring Tension Less Than Ten)

Machine Data:

$$F_{rad} = MR\omega^2$$

$$\omega = N_{rpm} \left[\frac{2\pi}{60} \right]$$

M	R	N_{rpm}	ω	ω^2	F_{rad}

Direct Measure:

$$F_{dir} = M_{total}g$$

M	M_{added}	M_{total}	g	F_{dir}
			$9.789 \frac{m}{s^2}$	

Comparisons of the values for a tension less than ten:

% Difference between F_{rad} and F_{dir} = _____

Trial Two (Spring Tension Greater Than Ten)

Machine Data:

$$F_{rad} = MR\omega^2$$

$$\omega = N_{rpm} \left[\frac{2\pi}{60} \right]$$

M	R	N _{rpm}	ω	ω ²	F _{rad}

Direct Measure:

$$F_{dir} = M_{total}g$$

M	M _{added}	M _{total}	g	F _{dir}
			9.789 $\frac{m}{s^2}$	

Comparisons of the values for a tension greater than ten:

% Difference between F_{rad} and F_{dir} = _____

PHY2053 LABORATORY

Experiment Six

The Simple Pendulum

THEORY

A simple pendulum is a pendulum with only one "arm" and one pivot. As we shall see, however, there is nothing particularly simple about the mathematical description of the motion of a simple pendulum.

Consider a small spherical object--called a "bob"--of mass M suspended from one end of a light string of length ℓ . The other end of the string is attached to a pivot. (For this experiment, we are going to simplify the analysis by assuming that this pivot is frictionless.) The motion of the pendulum will be initiated by releasing the pendulum from rest at an initial angle φ_o measured relative to the vertical as represented below in Figure One. (We also do a free-body diagram of the bob at some arbitrary angle φ relative to the vertical.)

Figure One

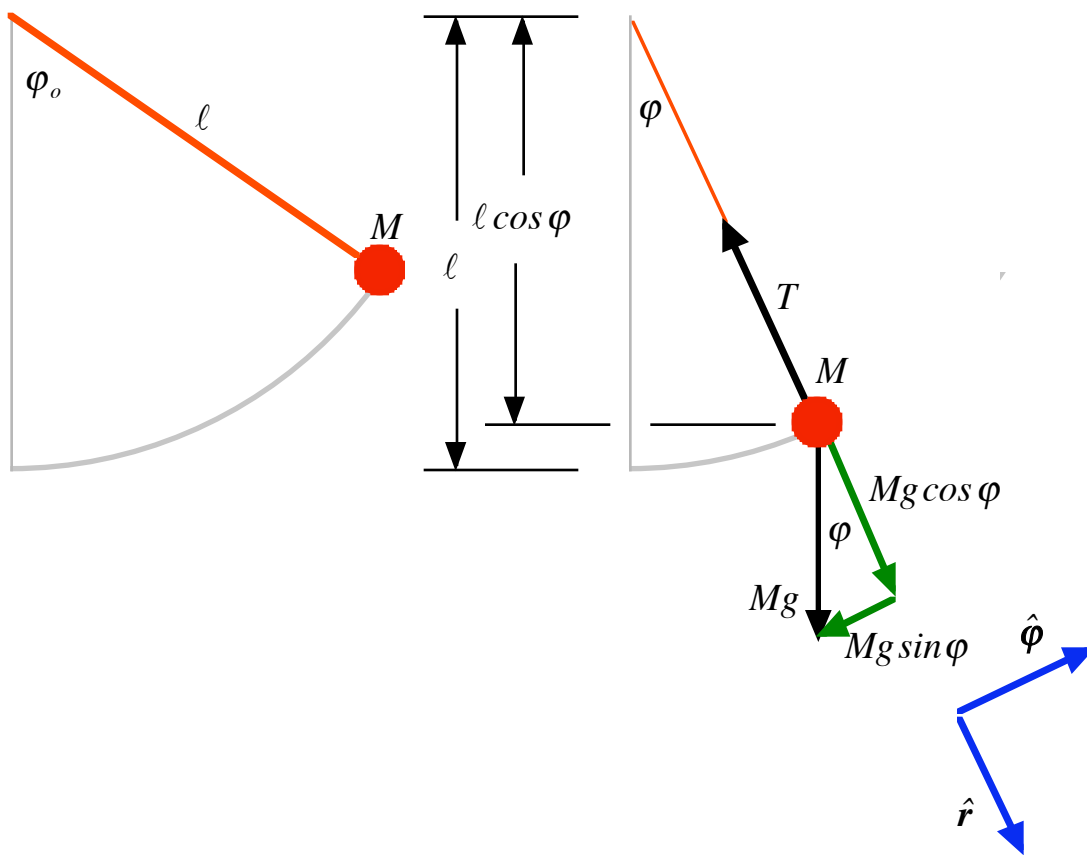

First, note that the bob is moving on a circular path of radius ℓ . So, when we sum the forces in the radial direction (\hat{r} direction), we find

$$Mg \cos \varphi - T = -M \frac{v^2}{\ell} \quad , \quad (1)$$

which implies that the magnitude of the tension is given by

$$T = M \left[g \cos \varphi + \frac{v^2}{\ell} \right] \quad . \quad (2)$$

Equation (2) makes it quite clear that the tension in the string is **not** constant. The tension depends on the speed v of the bob and the angular position φ . The tension in the string is a minimum when the bob is released since $v = v_o = 0$. So, the minimal tension is

$$T_{min} = T_o = Mg \cos \varphi_o \quad , \quad (3)$$

which is obviously smaller than the weight of the bob.

The maximum tension occurs when the bob is at the bottom of its arc. Here it is moving fastest and the cosine term is also largest--namely, one. We have

$$T_{max} = T_{bot} = M \left[g + \frac{v_{bot}^2}{\ell} \right] \quad . \quad (4)$$

The radially directed forces, however, are not responsible for the change in speed of the bob. Radially directed forces change the direction of the bob. We must look at the tangentially directed forces to understand how the bob changes speed. In the tangential direction we have

$$M \ell \alpha = -Mg \sin \varphi \quad . \quad (5)$$

We can rewrite equation (5) as

$$\alpha = \frac{d}{dt}[\omega] = \frac{d}{dt} \left[\frac{d\varphi}{dt} \right] = \frac{d^2 \varphi}{dt^2} = - \frac{g}{\ell} \sin \varphi \quad . \quad (6)$$

This equation is very difficult to solve. In fact, its solution involves an infinite series of terms. Once we have the solution to equation (6), we can then get an equation for the **period** of the pendulum. The period is the amount of time it takes the pendulum to make one complete oscillation and is signified by the Greek letter τ --(read tau). We have then

$$\tau = \left[2\pi \sqrt{\frac{\ell}{g}} \right] \left[1 + \frac{1}{4} \sin^2 \left(\frac{\varphi_o}{2} \right) + \frac{9}{64} \sin^4 \left(\frac{\varphi_o}{2} \right) + \dots \right] \quad , \quad (7)$$

where, recall, ℓ is the length of the pendulum, g is the magnitude of the acceleration due to the Earth's gravitational force, and φ_o is the starting angle of the pendulum measured from the vertical.

Small Angle Approximation

If we have a pendulum that is constrained to start from a small angle, and we measure the angle in *radians*, then it turns out that

$$\sin \varphi \approx \varphi \quad . \quad (8)$$

We call this the **small angle approximation**. Using equation (8) in equation (6), we have

$$\alpha = \frac{d}{dt}[\omega] = \frac{d}{dt} \left[\frac{d\varphi}{dt} \right] = \frac{d^2 \varphi}{dt^2} \approx - \frac{g}{\ell} \varphi \quad . \quad (9)$$

This equation has a simple solution of the form

$$\varphi = \varphi_o \cos(\omega' t) \quad , \quad (10)$$

where ω' is called the **angular frequency** defined by

$$\omega' = 2\pi f = \frac{2\pi}{\tau_{saa}} \quad , \quad (11)$$

where f is the regular frequency, i.e. the number of oscillations per second, and τ_{saa} is the period predicted by the small angle approximation. Substitution of equation (10) into equation (9) yields a solution for the period given by

$$\tau_{saa} = 2\pi\sqrt{\ell / g} . \quad (12)$$

Of course, one of the central aims of this experiment is to determine if equations (7) and (12) describe the actual periodicity of a simple pendulum.

PHY2053 LABORATORY

Experiment Six

The Simple Pendulum

Name:

Date:

Day and Time:

EQUIPMENT NEEDED

Two "Bobs" of Differing Materials
Stopwatch
Meter Stick

Pendulum Stand with Protractor
Mass Scale

PROCEDURE

Mass Dependence

- 1.) You should have two bobs made of different materials. Measure the mass of each bob and record the values on the data sheet.
- 2.) Take one of the spheres and attach it to the pendulum stand. Adjust it until it has a radial length equal to one *meter*. Record the actual radial length on the data sheet.
- 3.) In order to use the small angle approximation, the starting angle must be small. Pull the bob to the side so that its initial angular position is $\varphi_o = 15^\circ$, **measured with respect to the vertical**. (See Figure One above.) Release the bob from rest and note its motion.
- 4.) The greatest error in this experiment is in measuring the period. To reduce this error, it is best to take an average of **ten complete** oscillations. Take the total elapsed time and divide by the number of oscillations to get the average value for the period. It is also best to **start the stopwatch** when the pendulum passes the vertical moving to the left and **count zero**; one oscillation is when the pendulum next passes the vertical moving to the left. Of course, stop the counting and the watch at ten.
- 5.) Again, pull the bob aside to the $\varphi_o = 15^\circ$ mark and release it. Take the total time for the ten oscillations and divide by ten to get your first measure for the period. Record this value on the data sheet. Do this procedure three times.
- 6.) Repeat steps 2.) through 6.) for the other bob.
- 7.) Calculate the percent difference between the two average periods and record this value on the data sheet.

Length Dependence

- 8.) Take your most massive bob and return it to the pendulum stand. This time, suspend it with a length of $\ell = 20 \text{ cm} \equiv 0.2 \text{ m}$. Pull the bob aside to the $\varphi_o = 15^\circ$ mark and release it. Note the motion of the bob.
- 9.) Measure the total time for ten oscillations and divide by ten to get an average value for the period. Do this process three times and get an average for the three trials. Be sure to record the values on the data sheet.
- 10.) Repeat steps 7.) through 8.) for the following lengths and record your findings on the data sheet: (Do as many of these lengths as your string makes possible.)
40 cm, 60 cm, 80 cm, and 100 cm.

Angular Dependence

- 11.) With the most massive bob at a length of 1.00 m, measure the total time for the pendulum to make ten oscillations for a starting position of $\varphi_o = 15^\circ$ and divide by ten to get an average period value. Record your answer on the data sheet. Take a total of three measurements at this starting angle and record your values on the data sheet.
- 12.) Repeat step 11.) for the following starting angles: 20°, 30°, 40°, 50°, 60° and 70°. (Remember that you are keeping the length fixed! Also, if your bob hits the stand before you

complete ten oscillations, reduce the number of oscillations to five.)

Note that in the calculations to be performed, Theory 1 is the **small angle approximation** and is found in equation (12). Theory 2 represents the prediction that does not presuppose a small angle starting position, and is found in equation (7).

Below, is a table that gives us some sense of the magnitude of the error introduced by using a small angle approximation. Remember, we are replacing $\sin \varphi$ with φ . Be sure to note by what percentage these two quantities differ.

Small Angle Approximations

$\varphi(\text{degrees})$	$\varphi(\text{radians})$	$\sin \varphi$	% Difference
1	0.0175	0.0175	0.0051
2	0.0349	0.0349	0.0203
3	0.0524	0.0523	0.0457
4	0.0698	0.0698	0.0812
5	0.0873	0.0872	0.1270
6	0.1047	0.1045	0.1828
7	0.1222	0.1219	0.2489
8	0.1396	0.1392	0.3251
9	0.1571	0.1564	0.4116
10	0.1745	0.1736	0.5082
11	0.1920	0.1908	0.6151
12	0.2094	0.2079	0.7322
13	0.2269	0.2250	0.8595
14	0.2443	0.2419	0.9971
15	0.2618	0.2588	1.1449
16	0.2793	0.2756	1.3031
17	0.2967	0.2924	1.4715
18	0.3142	0.3090	1.6503
19	0.3316	0.3256	1.8395
20	0.3491	0.3420	2.0390
21	0.3665	0.3584	2.2490
22	0.3840	0.3746	2.4693
23	0.4014	0.3907	2.7001
24	0.4189	0.4067	2.9414
25	0.4363	0.4226	3.1932

DATA SHEET

Mass Dependence:

Common radial length: $\ell = 1.00 \text{ m}$.

Bob Masses

#	Material	Mass (kg)
M_1		
M_2		

Average Period ($\varphi_o = 15^\circ$)

<i>Trial #</i>	1	2	3	τ_{ave}
M_1				
M_2				

Length Dependence:

Average Period
($\varphi_o = 15^\circ$)

ℓ	Trial 1	Trial 2	Trial 3	τ_{ave}	τ_{saa}	% Diff
0.20 m					0.90	
0.40 m					1.27	
0.60 m					1.56	
0.80 m					1.80	
1.00 m					2.01	

Angular Dependence:

Radial Length:

$$\ell = 1.00 \text{ m .}$$

Average Period

φ_o	Trial 1	Trial 2	Trial 3	τ_{ave}	τ_{saa}	τ_{isa}	% Diff $\tau_{ave}; \tau_{saa}$	% Diff $\tau_{ave}; \tau_{isa}$
10°					2.01	2.01		
20°					2.01	2.03		
30°					2.01	2.04		
40°					2.01	2.07		
50°					2.01	2.11		
60°					2.01	2.15		
70°					2.01	2.21		

PHY2053 LABORATORY

Experiment Seven

Simple Harmonic Motion

THEORY

The Spring Constant

If we take a spring and hang it vertically, it will have a fixed vertical shape. I am going to call this the natural equilibrium position of the spring. If we next attach a mass M to the spring, it will stretch the spring some distance Δy . This new equilibrium position I will call the hanging equilibrium position of the spring and suspended mass. If we were to attach an even larger mass, the spring would stretch even more. (See Figure One below.)

Figure One

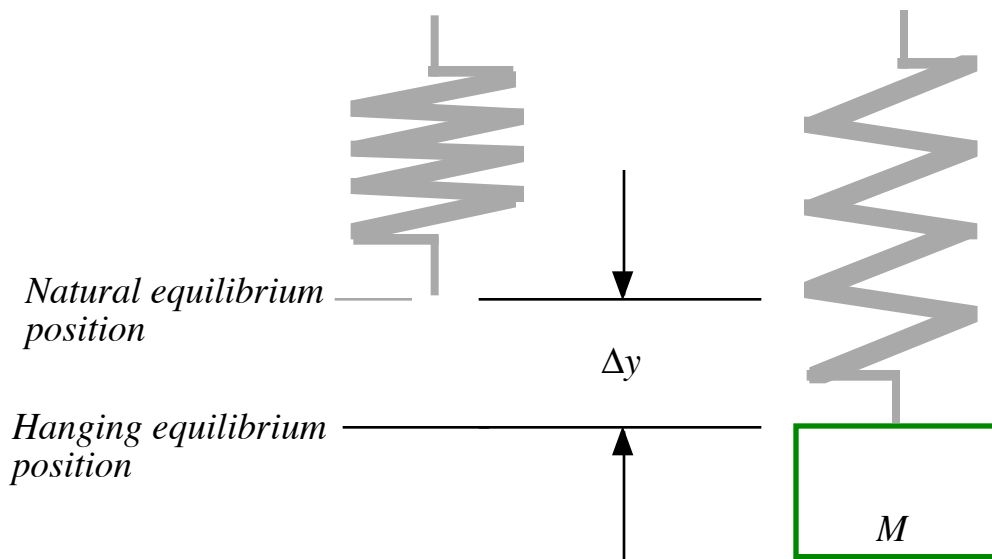

A free-body diagram of the suspended mass, indicates that three forces are acting on the spring. (See Figure Two below.) One force is the gravitational force exerted on the mass by the Earth, There is a buoyancy force exerted on the mass by the air. The third is the force exerted on the mass by the spring.

Figure Two

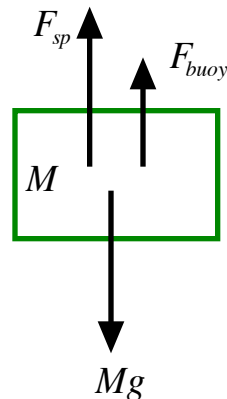

Since the suspended mass is in equilibrium, we can use Newton's second law to note:

$$F_{sp} = Mg - F_{buoy} . \quad (1)$$

Archimedes discovered that the buoyancy force is equal to the weight of the volume of the fluid displaced. In this case, the fluid displaced is the air. The volume is equal to that of the hanging mass M --we ignore the buoyancy force contributed by the spring itself. So, we can write

$$F_{buoy} = M_{air} g = [V_M \rho_{air}] g , \quad (2)$$

where V_M is the volume of the hanging mass and ρ_{air} is the average mass density of the air. In a similar fashion, we can write

$$Mg = [V_M \rho_M] g . \quad (3)$$

From equation (3), we have

$$V_M = M / \rho_M . \quad (4)$$

Substitution of equation (4) into equation (2) gives us

$$F_{buoy} = [(M / \rho_M) \rho_{air}] g = \frac{\rho_{air}}{\rho_M} Mg . \quad (5)$$

$$F_{sp} = Mg - \frac{\rho_{air}}{\rho_M} Mg = [1 - (\rho_{air} / \rho_M)] Mg . \quad (6)$$

The average mass density of the air is approximately $\rho_{air} \approx 1 \text{ kg} / \text{m}^3$, while the average mass density of a metal like steel, for example, is approximately $\rho_M \approx 7,800 \text{ kg} / \text{m}^3$. This makes the ratio of the densities approximately

$$\frac{\rho_{air}}{\rho_M} \approx \frac{1 \text{ kg} / \text{m}^3}{7,800 \text{ kg} / \text{m}^3} \approx 0.00013 , \quad (7)$$

and, therefore,

$$1 - \frac{\rho_{air}}{\rho_M} \approx 1 - 0.00013 \approx 0.99987 . \quad (8)$$

This is why we usually ignore buoyancy influences of the air; and we will ignore the air in this experiment.

So,

$$F_{sp} = Mg . \quad (9)$$

As you will see today, the magnitude of the spring force is directly proportional to the distance a spring is stretched (or compressed) as long as we do not stretch it far enough to permanently deform it. (The maximum amount of stretching the spring can withstand without permanent deformation is called the **elastic limit**.) Within the elastic limit, then, the magnitude of the spring force is proportional to the displacement of the spring, and we write

$$F_{sp} \propto \Delta y . \quad (10)$$

To make this an equation, we need a **constant of proportionality**. We call this specific constant of proportionality **the spring constant** and signify it with the symbol k_{sp} . (The spring constant tells us about how stiff a spring is.) This transforms the proportionality expressed in (10) into the following equation:

$$F_{sp} = k_{sp} \Delta y . \quad (11)$$

Next, equating (9) and (11) we have

$$k_{sp} \Delta y = Mg , \quad (12)$$

and, therefore,

$$\Delta y = \left(\frac{g}{k_{sp}} \right) M . \quad (13)$$

Equation (13) shows us how we can measure the spring constant k_{sp} for a specific spring. If we measure the distances a spring is stretched by differing masses, we can plot that data using equation (13). Since this equation is linear, we will get a straight line. We can measure the slope of this line and then solve for k_{sp} .

Simple Harmonic Motion

A horizontal spring is attached to a block of mass M . The block is constrained to move over a level, frictionless surface. Initially, the spring is in equilibrium--neither stretched nor compressed. Next, the mass is compressed a distance x , as represented below in Figure Three. If we release the block, it will oscillate back and forth on the level surface.

Figure Three

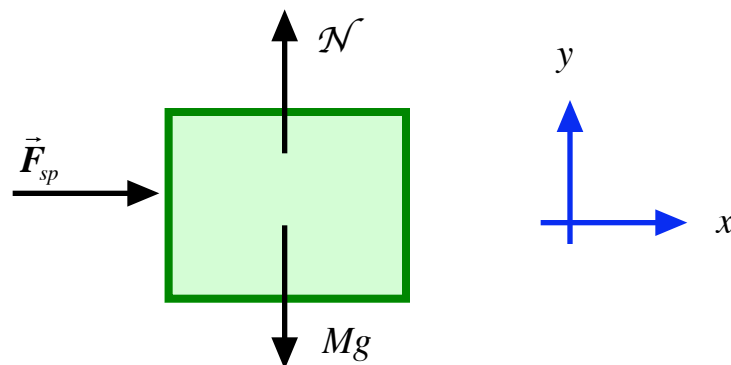
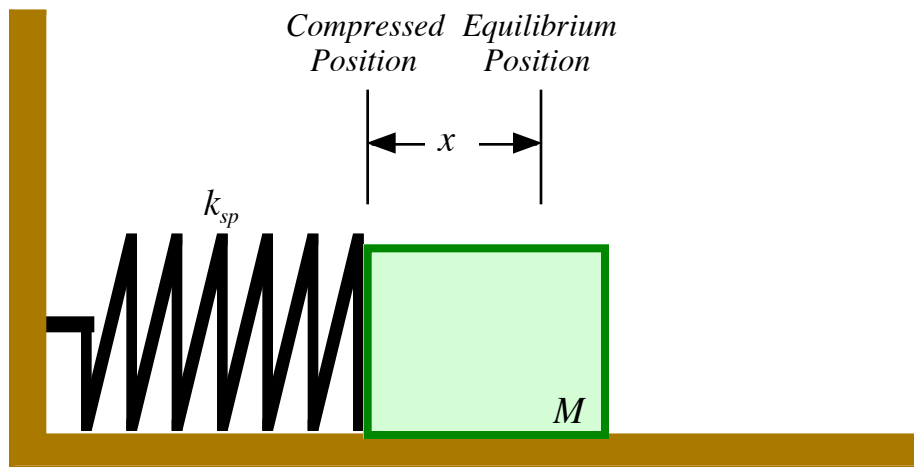

Newton's second law requires

$$-k_{sp}x = Ma_x, \quad (14)$$

and, therefore,

$$a_x = \frac{d^2x}{dt^2} = -\left(\frac{k_{sp}}{M}\right)x. \quad (15)$$

The solution of the differential equation (15) has the form

$$x = x_o \cos(\omega't), \quad (16)$$

where the angular frequency ω' is a constant. Using this form, we find, for the instantaneous velocity, that

$$v = \frac{dx}{dt} = \frac{d}{dt}[x_o \cos(\omega't)] = -\omega'x_o \sin(\omega't). \quad (17)$$

The acceleration is given by

$$a = \frac{dv}{dt} = \frac{d}{dt}[-\omega'x_o \sin(\omega't)] = -\omega'^2x_o \cos(\omega't). \quad (18)$$

Substitution of equations (18) and (16) into equation (15) gives us

$$-\omega'^2x_o \cos(\omega't) = -\left(\frac{k_{sp}}{M}\right)x_o \cos(\omega't). \quad (19)$$

Equation (19) is true if and only if

$$\omega'^2 = \left(\frac{k_{sp}}{M}\right). \quad (20)$$

The angular frequency ω' is

$$\omega' = \sqrt{\frac{k_{sp}}{M}} = \frac{2\pi}{\tau}. \quad (21)$$

The period is

$$\tau = 2\pi \sqrt{\frac{M}{k_{sp}}}. \quad (22)$$

If we square both sides of equation (22) we find

$$\tau^2 = \left[\frac{4\pi^2}{k_{sp}}\right]M. \quad (24)$$

PHY2053 LABORATORY

Experiment Seven

Simple Harmonic Motion

Name:

Date:

Day and Time:

EQUIPMENT NEEDED

Spring On A Stand With A Scale
Slotted Masses

50 gram Mass Pan
Stopwatch

PROCEDURE

Measuring the Spring Elongation :

1.) The first thing we want to do is “zero” our spring scale. With the spring hanging under its own weight only, attach the 50 gram mass pan to the spring. Squeeze the two flanges on the back of the *centimeter* scale and at the same time slide the scale so that its zero lines up with the bottom edge of the mass pan. Next, when you place a mass M onto the pan, it will stretch the spring a distance Δy . (See Figure Five below.)

Figure Five

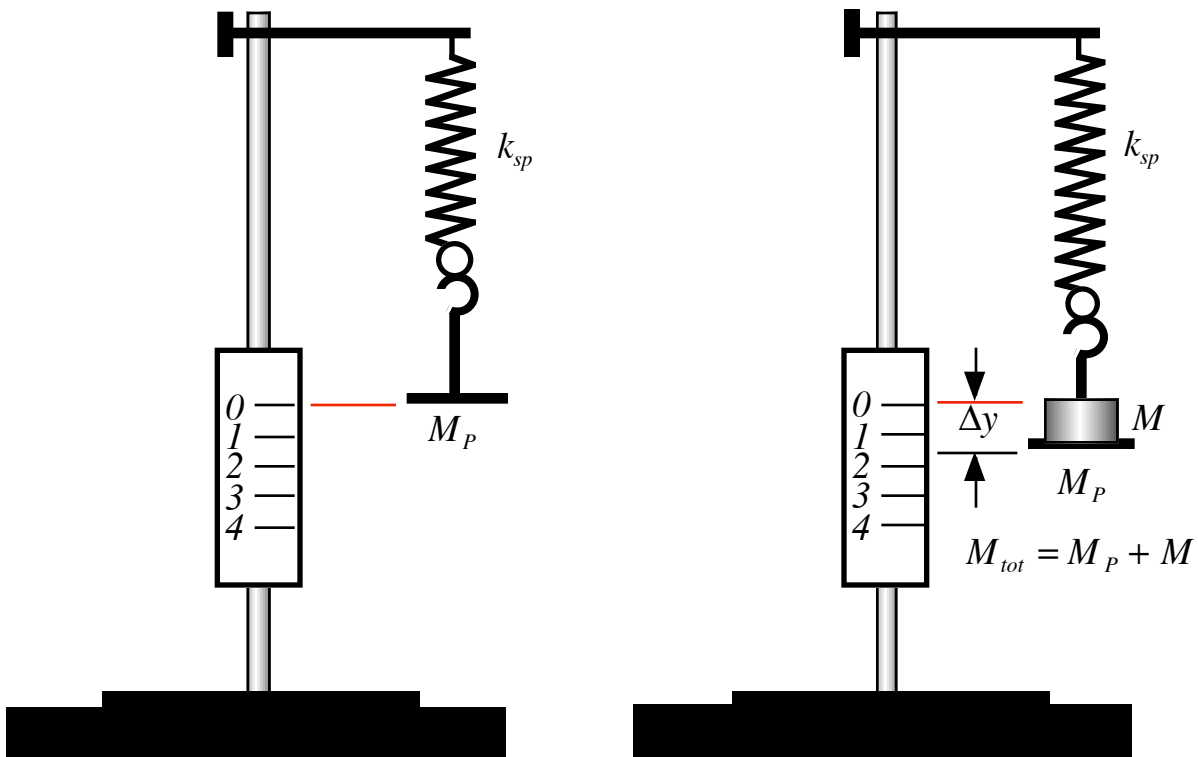

- 2.) Place 50 grams onto the pan. This should give a **total mass** of 100 grams. Measure the distance the spring is stretched and record this value on the data sheet.
- 3.) Repeat the process described in step two, for **added masses** of 150, 200, 250, 300, and 350 grams.

Measuring the Period of Oscillation τ :

- 4.) Slide the scale to the top of the holder to get it out of the way.
- 5.) Place a mass of 150 grams onto the pan and let the spring stretch to its equilibrium position. You should now have a total mass of 200 grams on the pan.
- 6.) In this step, we are going to use a stopwatch to measure the **total** amount of **time** it takes this mass to make **five complete** oscillations. Set the stopwatch to zero. **Gently** push the mass upward a very small distance. Release the mass and measure the time for **five complete** oscillations and then divide by five to get your first measure of the period of the simple harmonic motion. Record this value on the data sheet under trial one. Do this again two more times so that you have a total of three trial measurements.
- 7.) Repeat steps five and six for total masses of 250, 300, 350, 400, and 450 grams.

Graphing and Other Things to Do

- 1.) Using the data collected in the “**Measuring the Spring Elongation,**” construct a graph of Δy versus M_{tot} on the graph paper provided. Draw a **single straight line** that appears to best fit your data.
- 2.) Once you have the graph drawn, calculate the slope of this graph and record the value on the data sheet.
- 3.) Using equation (5), calculate the spring constant and record the value on the data sheet as $k_{sp,1}$.
- 4.) Using the data collected in the “**Measuring the Period τ ,**” construct a graph of τ_{ave}^2 versus M_{tot} on the graph paper provided. Draw a **single straight line** that appears to best fit your data.
- 5.) Once you have the graph drawn, calculate the slope of this graph and record the value on the data sheet.
- 6.) Using equation (9), calculate the spring constant and record the value on the data sheet as $k_{sp,2}$.
- 7.) Calculate the percent difference between the two values you have found for the spring constant.
- 8.) If time permits:
 - a) use the least count and standard deviation calculations, when possible, to estimate the error in the measurement of the spring constant for each method used.
 - b) determine what is the best estimate of the value of the spring constant.

Data Sheet

Measuring the Spring Elongation:

M_{total} (grams)	Δy (cm)
50	0
100	
150	
200	
250	
300	
350	

Slope of the graph of Δy versus M_{tot} :

$$slope = \text{_____} \frac{m}{kg} .$$

Equation (13) implies that

$$slope = \frac{g}{k_{sp}} .$$

So, your data suggests the spring constant has a value of:

$$k_{sp,1} = \text{_____} \frac{N}{m} .$$

Measuring the Period τ :

M_{tot} (gr)	<i>Trial One</i> (s)	<i>Trial Two</i> (s)	<i>Trial Three</i> (s)	τ_{ave} (s)	τ_{ave}^2 (s ²)
200					
250					
300					
350					
400					
450					

Slope of the graph of τ^2 versus M :

$$slope = \frac{\text{_____}}{\text{_____}} \frac{s^2}{kg} .$$

Equation (24) implies that

$$slope = \frac{4\pi^2}{k_{sp}} .$$

So, your data suggests the spring constant has a value of:

$$k_{sp,2} = \underline{\hspace{10cm}} \frac{N}{m} .$$

$$\% \text{ Diff } k_{sp,1} \text{ and } k_{sp,2} = \underline{\hspace{10cm}} .$$

The Vertical Displacement of a Spring as a Function of Mass

$\Delta y(m)$

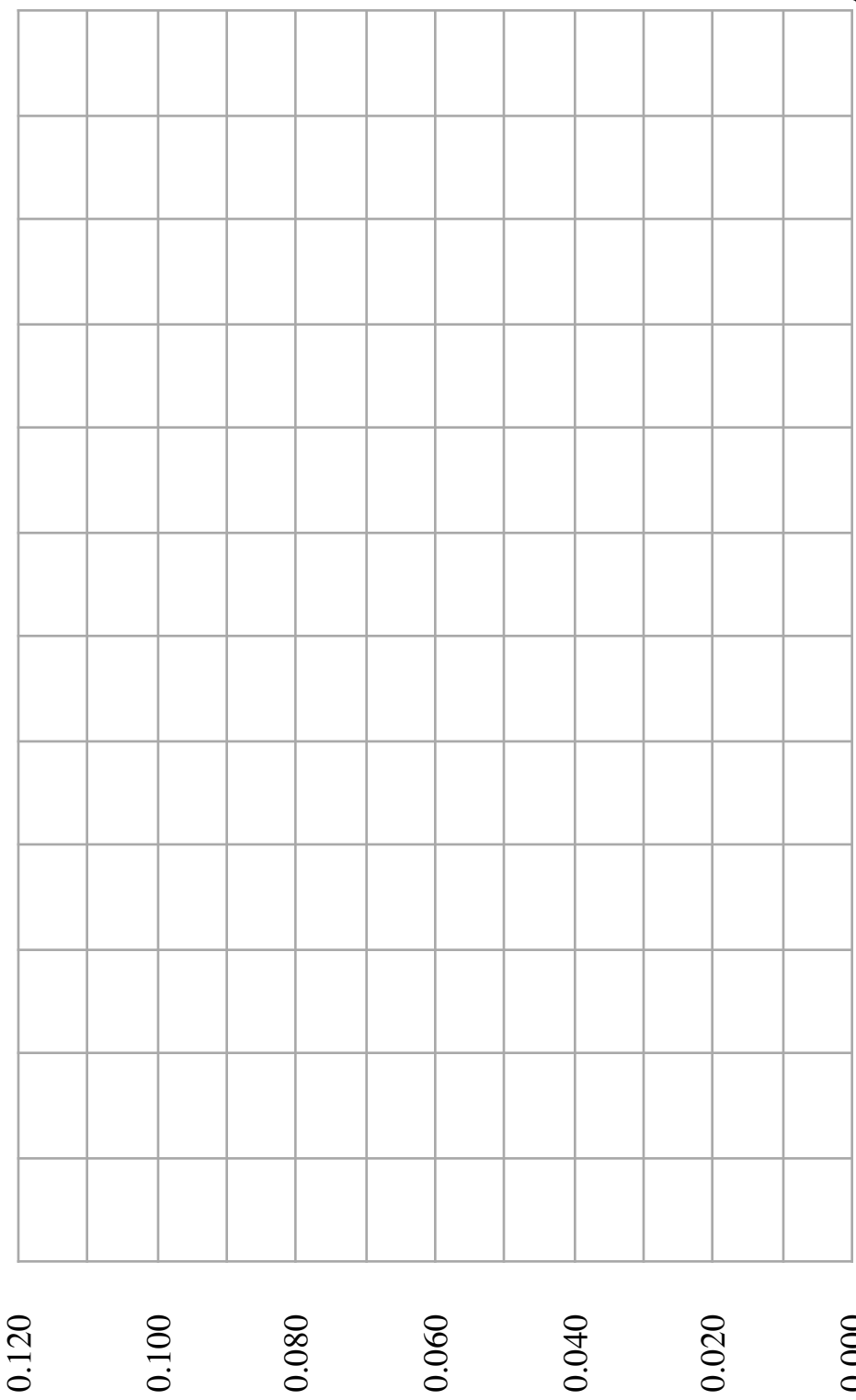

$M_{tot} (kg)$

0.050 0.100 0.200 0.300 0.400 0.500 0.600

HI 74

The Square of the Oscillator Period as a Function of Mass

$\tau^2 (s^2)$

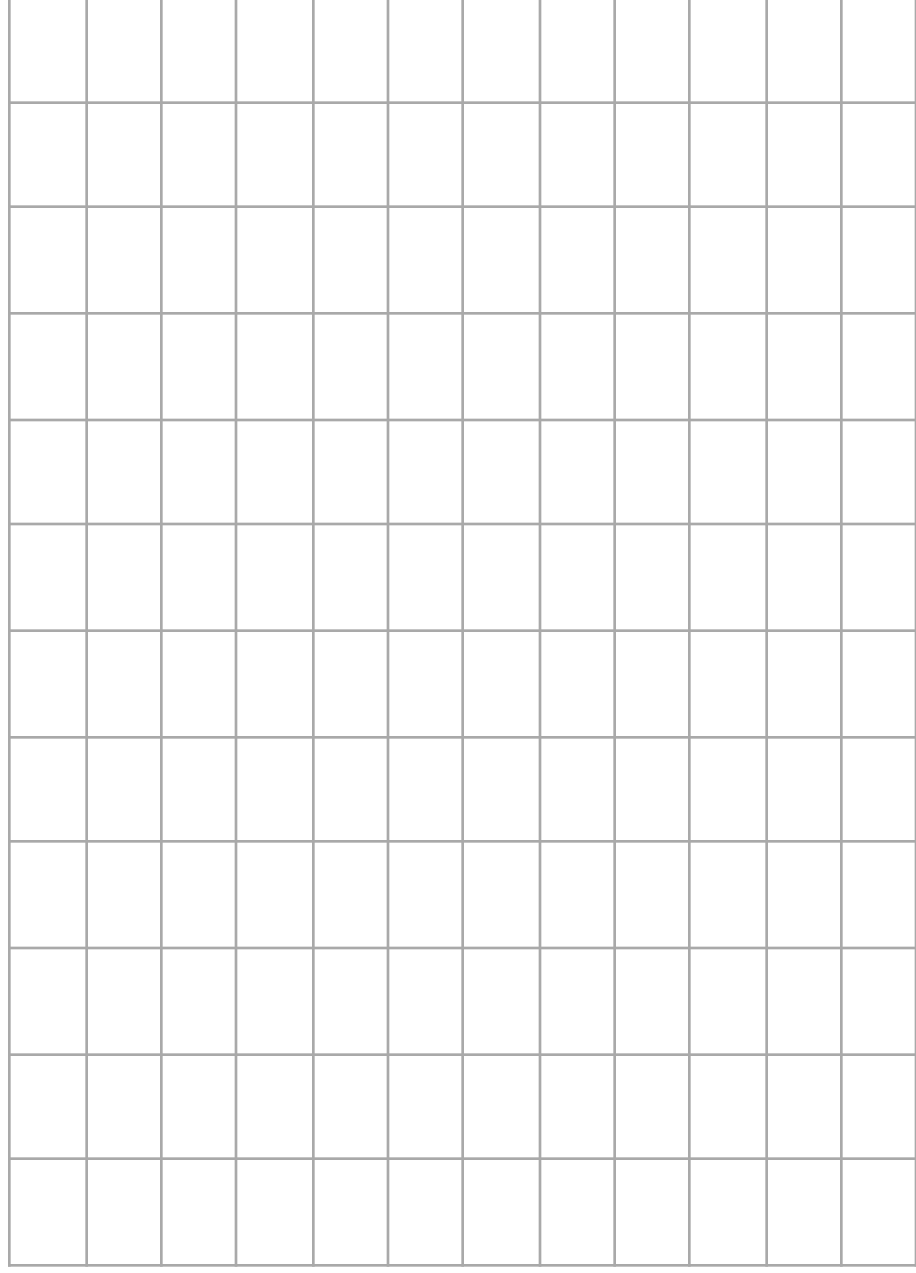

$M_{rot} (kg)$

0.000

0.100

0.200

0.300

0.400

0.500

0.600

HI 7-5

PHY2053 LABORATORY

***A Quantitative Interlude:
The Theory of Torques***

THEORY

Consider a stick one *meter* in length--these sticks are found often in physics labs. I hope it seems reasonable to you that if you wanted to balance this stick on your finger, then the place to do this would be somewhere very near the middle of the stick. (It is implicit in this line of reasoning that the material which makes up the meter stick is homogeneous. This "balancing point" is called the center of mass.) A balanced meter stick is represented below in Figure One. (Note that I have placed the **origin** of a Cartesian coordinate system at the center of mass of the meter stick.)

Figure One

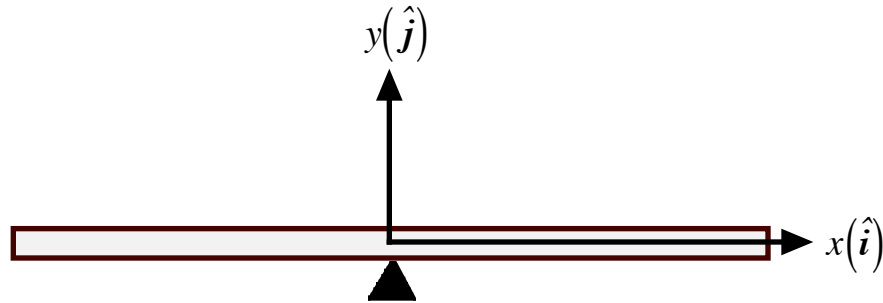

Note : $z(\hat{k})$ Is out of the page.

Now that we have a balanced meter stick, if I were to place a small mass M on the stick at some arbitrary distance x from the balancing point, as represented in Figure Two below, then the meter stick would rotate clockwise--as we view it--about the origin of the coordinate system. In other words, the rotational state of motion of the meter stick would **change** due to the added weight. In physics, we call any physical agency which gives rise to a **change in the rotational state of motion**, a **torque**.

Figure Two

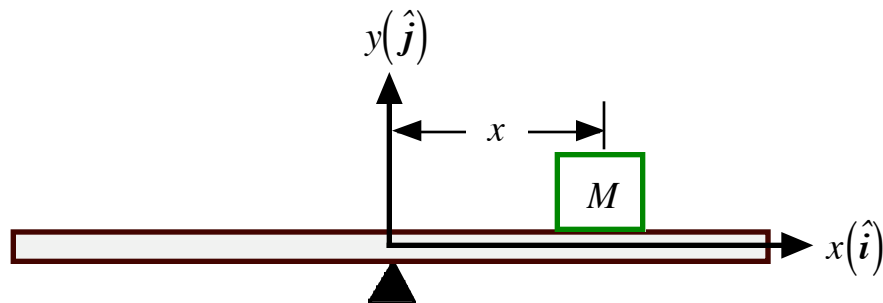

Note : $z(\hat{k})$ Is out of the page.

(The net torque is the rotational analog to the net force. Recall that a net force causes a physical thing to accelerate.) In this class, I am going to use an upper case Greek letter gamma, $\vec{\Gamma}$, to signify a torque. (Note that torques are vector quantities.) A torque is defined by

$$\vec{\Gamma}_O = \vec{r} \times \vec{F}, \quad (1)$$

where O is the point about which the rotation takes place, \vec{F} is the off-axis force which gives rise to the rotation, and \vec{r} is the vector that runs from O to the actual point where the force \vec{F} is being applied. The " \times " represents a specific kind of vector multiplication that we call the "cross product," or the "vector product." Understanding the meaning of the vector product and how to calculate with it is the central aim of this discussion.

If we use the example represented in Figure Two above, we can write

$$\vec{F} = -Mg \hat{j}, \quad (2)$$

while

$$\vec{r} = x \hat{i}. \quad (3)$$

Therefore, the torque about the origin is

$$\vec{\Gamma}_O = [x \hat{i}] \times [-Mg \hat{j}] = -xMg [\hat{i} \times \hat{j}]. \quad (4)$$

But what in the world is meant by $\hat{i} \times \hat{j}$? Understanding how to multiply unit vectors is the key to understanding the cross product.

Please consider carefully the diagram below in Figure Three. The meaning of the cross product is represented there.

Figure Three

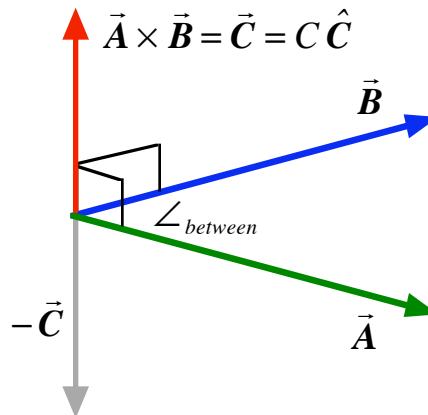

First, note that when we multiply vectors \vec{A} and \vec{B} , we get **another vector**, which I have called \vec{C} . Notice also that \vec{C} is perpendicular to both vectors \vec{A} and \vec{B} ! Unfortunately, there are two directions to the line that is perpendicular to both \vec{A} and \vec{B} , but only one of the directions is correct! (This is exactly like the problem we have with the Cartesian coordinate system. The z -axis is perpendicular to both the x -axis and the y -axis. So what is the correct direction for the positive branch of the z -axis?)

Using the fact that vectors have a magnitude and a direction, we can write

$$\vec{A} \times \vec{B} = [A \hat{A}] \times [B \hat{B}] = AB [\hat{A} \times \hat{B}]. \quad (5)$$

All of the interesting “vector stuff” takes place in the cross product of the unit vectors. **In general**, we have

$$\hat{\mathbf{A}} \times \hat{\mathbf{B}} = \sin \angle_{\text{between}} \hat{\mathbf{C}} \quad (6)$$

where \angle_{between} is the **small** angle between vectors $\vec{\mathbf{A}}$ and $\vec{\mathbf{B}}$, and $\hat{\mathbf{C}}$ is a unit vector that is perpendicular to both vectors $\vec{\mathbf{A}}$ and $\vec{\mathbf{B}}$ in the “**right-hand**” sense. (I will signify the angle between with \angle_{bet} .) By the right-hand sense, I mean that if one aligns the fingers of one’s **flat** right hand in the direction of vector $\vec{\mathbf{A}}$, with the palm facing in the direction of vector $\vec{\mathbf{B}}$, then an extended right thumb will point in the direction of vector $\vec{\mathbf{C}}$. (See the highly stylized Cubist rendering of a severed right-hand below! Now you know why I did not go into art to make a living!) This is why a Cartesian coordinate system is said to be right-handed.

The Right – Hand Rule

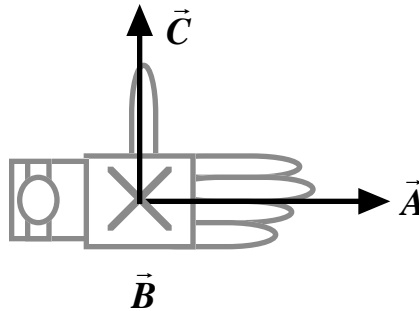

(The palm is facing into the page!)

One can verify, using the right-hand rule described above, and equation (6), that

$$\hat{\mathbf{i}} \times \hat{\mathbf{j}} = \hat{\mathbf{k}} \quad (7)$$

$$\hat{\mathbf{j}} \times \hat{\mathbf{k}} = \hat{\mathbf{i}} \quad (8)$$

$$\hat{\mathbf{k}} \times \hat{\mathbf{i}} = \hat{\mathbf{j}} \quad (9)$$

while in the reverse order we have

$$\hat{\mathbf{j}} \times \hat{\mathbf{i}} = -\hat{\mathbf{k}} \quad (10)$$

$$\hat{\mathbf{k}} \times \hat{\mathbf{j}} = -\hat{\mathbf{i}} \quad (11)$$

$$\hat{\mathbf{i}} \times \hat{\mathbf{k}} = -\hat{\mathbf{j}} \quad (12)$$

The order of multiplication is important in the cross product. The cross product is **not commutative**. Also note that any unit vector crossed with itself is zero. That is,

$$\hat{\mathbf{i}} \times \hat{\mathbf{i}} = \hat{\mathbf{j}} \times \hat{\mathbf{j}} = \hat{\mathbf{k}} \times \hat{\mathbf{k}} = \hat{\mathbf{r}} \times \hat{\mathbf{r}} = \sin 0^\circ = 0 \quad (13)$$

To return to the situation described in Figure Two, we have a net torque about the origin

$$\vec{\Gamma}_o = [x \hat{\mathbf{i}}] \times [-Mg \hat{\mathbf{j}}] = -xMg [\hat{\mathbf{i}} \times \hat{\mathbf{j}}] = -xMg \hat{\mathbf{k}} \quad (14)$$

which produces a clockwise rotation of the system. Net torques rotate--produce an angular acceleration of physical systems--just as net forces linearly accelerate physical systems.

It might occur to you that we might be able to bring the system back in balance by putting another mass M' somewhere on the other side of the pivot point. The relative magnitudes of M'

and M , and the distance x , will determine how far to the left of the origin we have to place M' . This situation is represented in Figure Four below.

Figure Four

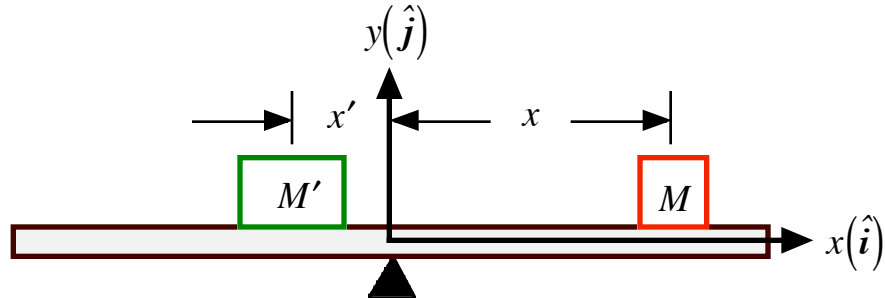

Note: $z(\hat{k})$ Is out of the page.

I hope that it seems reasonable to you that this situation can be in balance only if there is no net torque. That is, if we add the two torques about the origin, the sum must be equal to zero. So, for **rotational equilibrium**, we require

$$\vec{\Gamma}_o + \vec{\Gamma}'_o = 0 \quad . \quad (15)$$

First, note that

$$\vec{\Gamma}'_o = [-x' \hat{i}] \times [-M'g \hat{j}] = x'M'g [\hat{i} \times \hat{j}] = x'M'g \hat{k} \quad . \quad (16)$$

So, to restore equilibrium, we require

$$-xMg \hat{k} + x'M'g \hat{k} = 0 \quad , \quad (17)$$

and

$$x'M' = xM \quad . \quad (18)$$

Rotational equilibrium requires that the moment arms are related by

$$x' = \left[\frac{M}{M'} \right] x \quad , \quad (19)$$

or, equivalently, that the masses be related by

$$M' = \left[\frac{x}{x'} \right] M \quad . \quad (20)$$

Finally, in Figure Five below, I have drawn a free-body diagram of all of the forces that are acting on the meter stick. We conclude this discussion by stating that the **necessary and sufficient** conditions for **static equilibrium** of an extended physical thing are

$$\sum \vec{F} = 0 \quad , \quad (21)$$

and

$$\sum \vec{\Gamma}_{any\ axis} = 0 \quad . \quad (22)$$

Figure Five

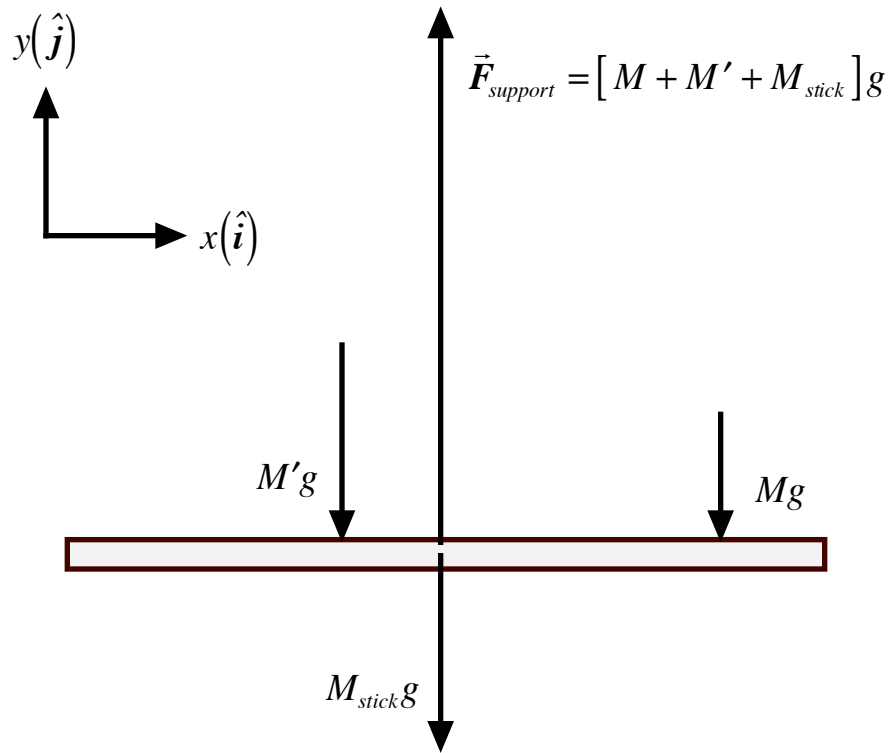

PHY2053 LABORATORY

Experiment Eight

Torques and Rotational Equilibrium

THEORY

Figure One

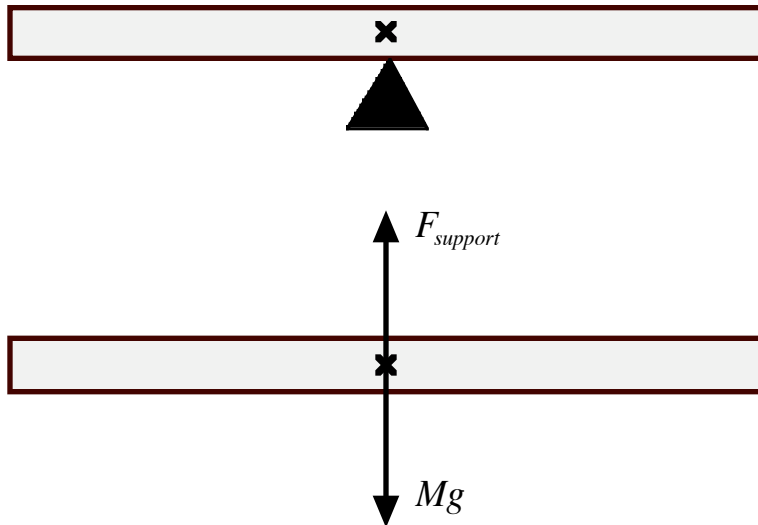

A uniformly thin rod has a mass M and a length ℓ . There is a point--the center of mass--at which this rod can be balanced. This state of affairs is represented above in Figure One. (Included in Figure One is a free-body diagram. Note that the gravitational force acts at the center of mass.)

If we were to move the balance point away from the center of mass, then the meter stick would rotate about the pivot point. (This state of affairs is represented below in Figure Two.) The force action responsible for this rotation is the gravitational force. Force actions that produce rotations are called torques.

Figure Two

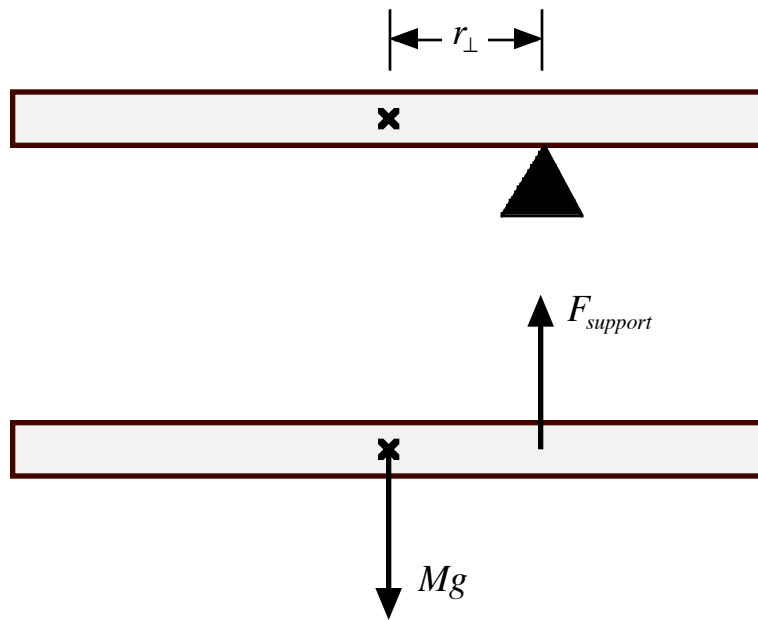

The formal definition of a torque is given by

$$\vec{\Gamma}_O = \vec{r} \times \vec{F}, \quad (1)$$

where \vec{r} is the vector that runs from the axis of rotation to the point where the force is applied, and \vec{F} is the acting force. (This state of affairs is represented in Figure Three below.) When we go to calculate a torque we have

$$\vec{\Gamma}_O = \vec{r} \times \vec{F} = [r \hat{r}] \times [F \hat{F}] = rF [\hat{r} \times \hat{F}]. \quad (2)$$

The question is what do we get when we take the cross product of two unit vectors. In this case, we have

$$\hat{r} \times \hat{F} = \sin \angle_{bet} \hat{\Gamma}_O,$$

where $\hat{\Gamma}_O$ is the direction of the torque and is perpendicular to both \hat{r} and \hat{F} in the right hand sense. Technically, we can write

$$\begin{aligned} [\sin \angle_{bet} \hat{i} - \cos \angle_{bet} \hat{j}] \times [-\hat{j}] &= [-\sin \angle_{bet} (\hat{i} \times \hat{j})] + [\cos \angle_{bet} (\hat{j} \times \hat{j})] \\ &= [-\sin \angle_{bet} (\hat{i} \times \hat{j} = \hat{k})] + [\cos \angle_{bet} (\hat{j} \times \hat{j} = 0)] = -\sin \angle_{bet} \hat{k}. \end{aligned} \quad (3)$$

So, for our example,

$$\vec{\Gamma}_O = \vec{r} \times \vec{F} = -[r (\sin \angle_{bet}) F] \hat{k} = -r_{\perp} F \hat{k}, \quad (4)$$

where r_{\perp} is the perpendicular distance--the shortest distance from the axis to the line of action of the force. The magnitude of a torque is given by

$$\Gamma = r_{\perp} F. \quad (5)$$

Figure Three

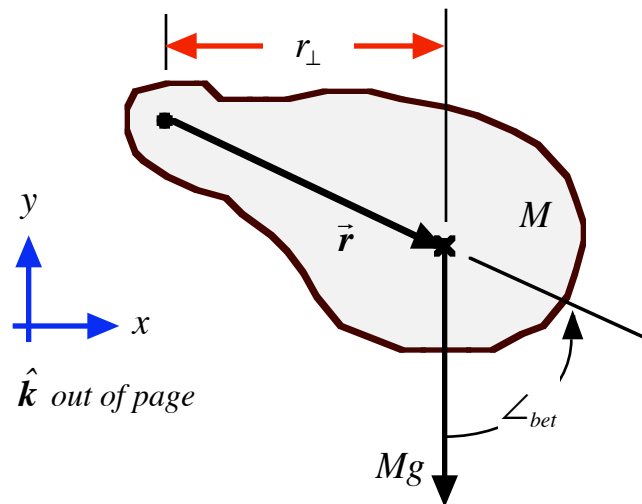

PHY2053 LABORATORY

Experiment Eight

Torques and Rotational Equilibrium

Name:

Date:

Day and Time:

EQUIPMENT NEEDED

One One-meter Stick
One Pivot Hanger
Two Mass Hangers

One Pivot Stand
Two 50 gram Mass Pans
One Set of Slotted Masses

PROCEDURE

Measuring the Mass of the "Players"

- 1.) Measure the mass of the meter stick, M_S , and record this value on the data sheet. (Use MKS units.)
- 2.) Measure the mass of the pivot hanger, M_{PH} , and record this value on the data sheet.
- 3.) Take one mass hanger and one mass pan and place the two together on the scale. Record this total value as M_{H1} on the data sheet. I will call this pair **hanger one**.
- 4.) Take the other mass hanger and mass pan and place them together on the scale. Record this total value as M_{H2} on the data sheet. I will call this pair **hanger two**. (Make sure to keep each mass hanger properly paired with its mass pan.)

Figure One

“Some Of The Players”

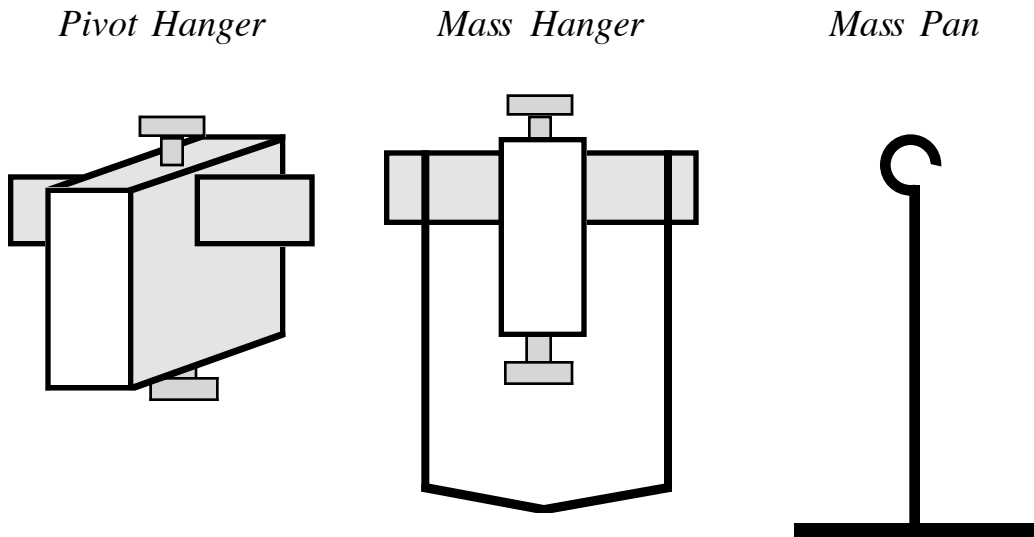

Finding The Center Of Mass Of The Meter Stick

- 5.) Slide the pivot hanger onto the meter stick with the **blades at the top** of the stick. **Do not lock the hanger in place**; you should be able to slide the hanger along the meter stick. (To help you orient the following directions, keep the zero of the meter stick to your left. See Figure Two below.)
- 6.) Place the meter stick and hanger onto the pivot stand with the blades resting in the pivot V-slot. Slowly, move the meter stick relative to the pivot stand until the meter stick is horizontal and completely level. Now you can lock the pivot hanger. Note the location on the meter stick which coincides with the center of mass of the meter stick, and record this value, X_{CM} , on the data sheet.

The meter stick is free to pivot on the blades of the pivot hanger that is attached to the stick. We can treat the stick and pivot hanger together as the system. As the system is not moving, it is in static equilibrium. The forces acting on the system are shown in the free-body diagram represented in Figure Two below.

Figure Two

A Balanced Meter Stick

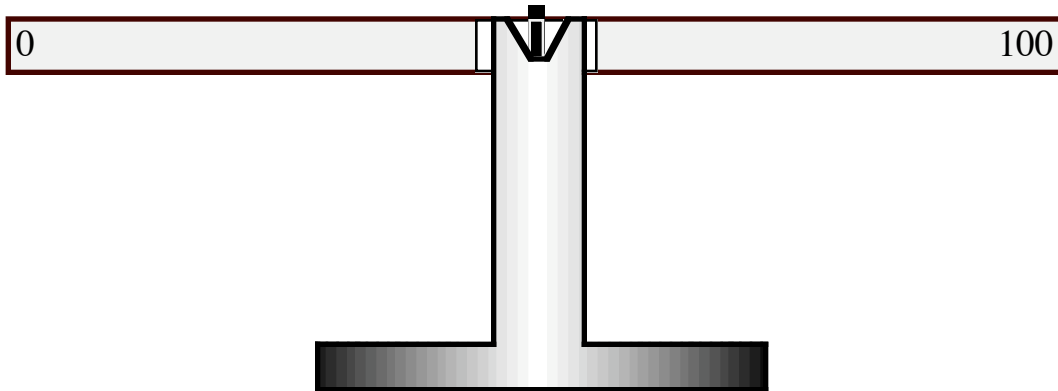

A Free-Body Diagram of the Balanced Meter Stick

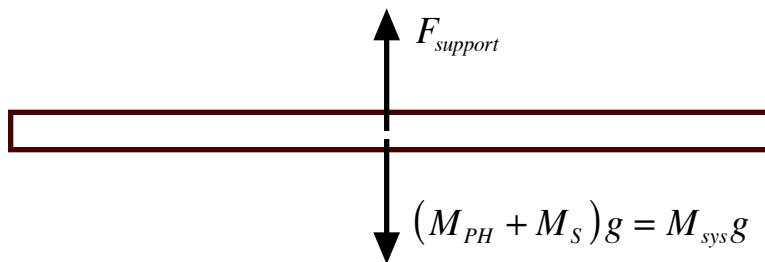

A Rotational Equilibrium Exercise (See Figure Three)

- 7.) Place one 200 gram mass onto **hanger one** and then fix hanger one at the 20 cm mark of the meter stick. (This will, of course, remove the system from a state of rotational equilibrium. You will have to use your hands and the table top to maintain order. Also, it is assumed here that the 0 is at the left end of the meter stick.) Calculate the distance from hanger one to the pivot, $r_{\perp 1}$, and record this value on the data sheet.
- 8.) Place 300 grams of mass on **hanger two**. Put hanger two onto the right side of the stick and move it along the stick until you find the location at which the stick will be in rotational equilibrium and lock the hanger. Measure the distance from the pivot to hanger two, $r_{\perp 2}$, and record this value on the data sheet.
- 9.) Calculate the magnitude of the counterclockwise torque produced by M_1 about the pivot, where, recall, $M_1 = M_{H1} + 0.200 \text{ kg}$. Record this value on the data sheet.
- 10.) Calculate the magnitude of the clockwise torque produced by M_2 about the pivot, where, recall, $M_2 = M_{H2} + 0.300 \text{ kg}$. Record this value on the data sheet.

Figure Three

The First Rotational Equilibrium Exercise

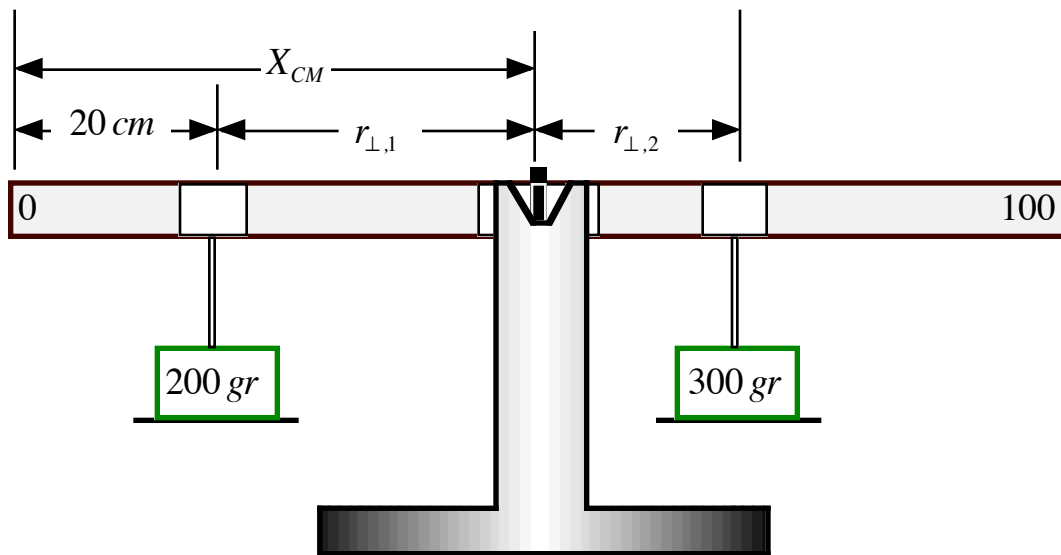

Free-Body Diagram

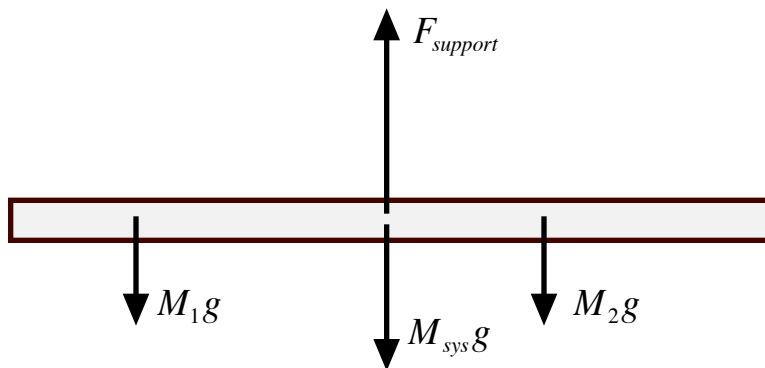

A Second Rotational Equilibrium Exercise (See Figure Four)

- 11.) Place 400 grams onto **hanger one** and then fix hanger one at the 30 cm mark of the meter stick. (This will, of course, remove the system from a state of rotational equilibrium. You will have to use your hands and the table top to maintain order. Also, it is assumed here that the 0 is at the left end of the meter stick.) Calculate the distance from hanger one to the pivot, $r_{\perp 1}$, and record this value on the data sheet.
- 12.) Place 500 grams of mass on **hanger two**. Put hanger two onto the right side of the stick and move it along the stick until you find the location at which the stick will be in rotational equilibrium and lock the hanger. Measure the distance from the pivot to hanger two, $r_{\perp 2}$, and record this value on the data sheet.
- 13.) Calculate the magnitude of the counterclockwise torque produced by M_1 about the pivot,

where, recall, $M_1 = M_{H1} + 0.400 \text{ kg}$. Record this value on the data sheet.

14.) Calculate the magnitude of the clockwise torque produced by M_2 about the pivot, where, recall, $M_2 = M_{H2} + 0.500 \text{ kg}$. Record this value on the data sheet.

Figure Four

The Second Rotational Equilibrium Exercise

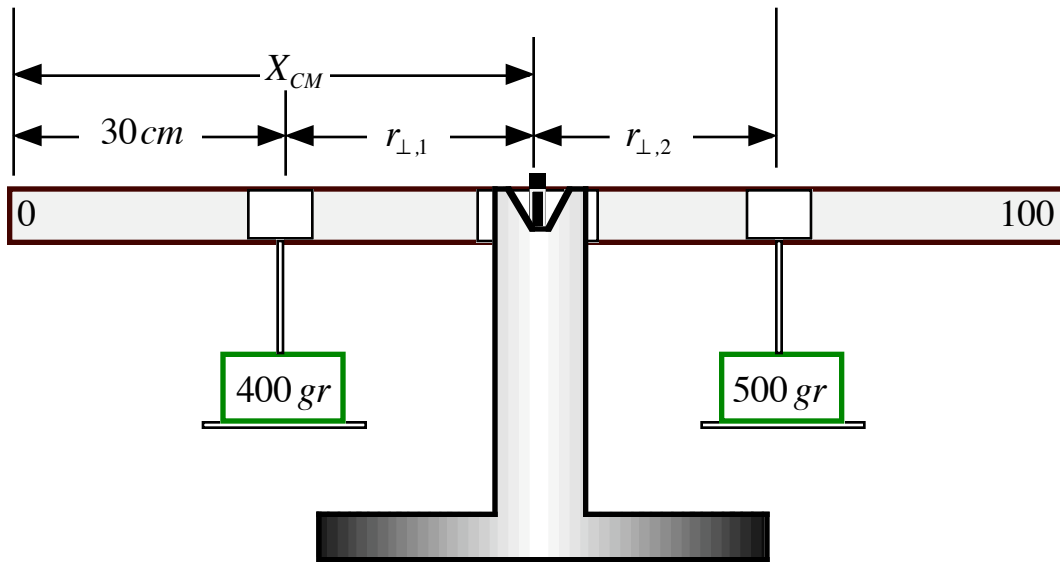

Free-Body Diagram

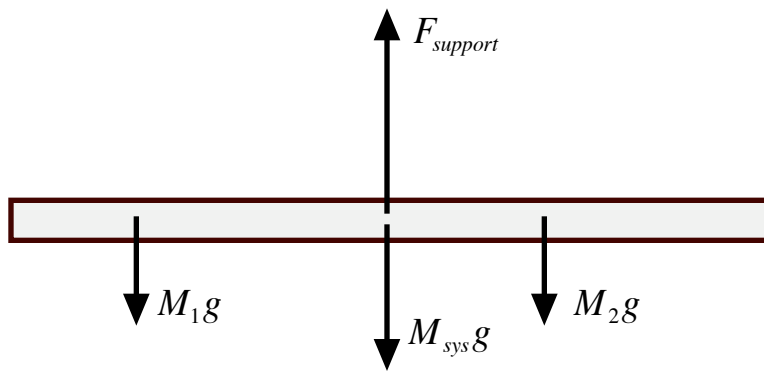

Another Method for Finding the Mass and the Center of Mass of the Meter Stick

In this exercise, we are going to act as if we do not know where the center of mass of the meter stick is and that we do not know the mass of the meter stick. We will assume that the center of mass is located a distance X from the left end of a meter stick of mass M . By working with two different rotational equilibrium configurations, we can generate two independent equations each with the two unknowns X and M . (See the analysis of this process below.)

15.) Move the blade pivot hanger to the 60 cm mark and place the blade onto the pivot stand. Using mass **hanger one**, determine experimentally the location, and the total amount of mass needed to completely balance the meter stick. (See Figure Five below.) Record on the data sheet, the location of this balancing mass, x_1 , **measured from the pivot**, and the total mass, M_1 , you have hanging at this location.

Figure Five

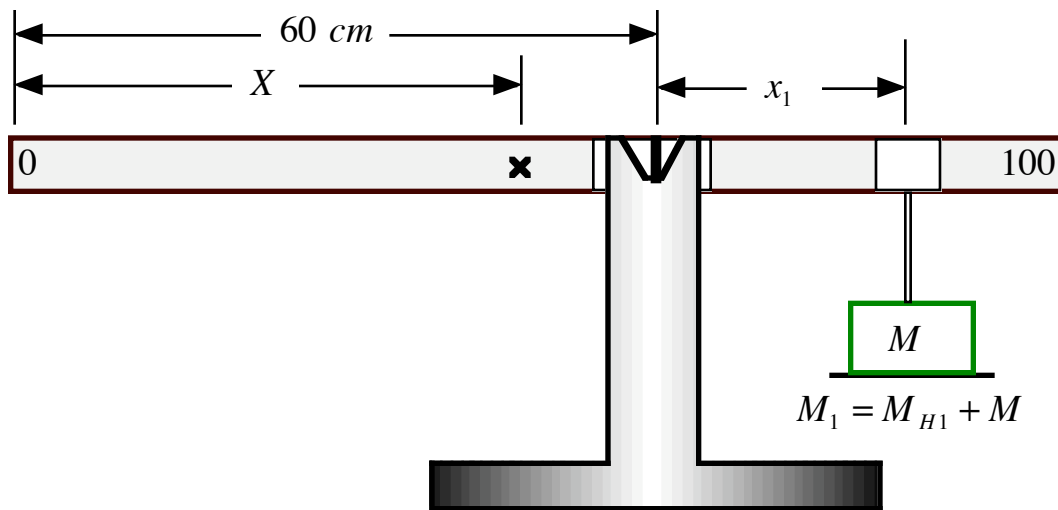

Free-Body Diagram

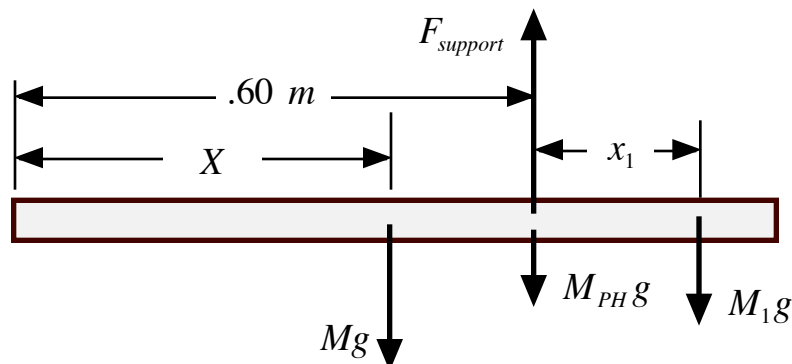

16.) Move the blade pivot hanger to the 70 cm mark and place the blade onto the pivot stand. Using mass **hanger two**, determine experimentally the location, and the total amount of mass needed to completely balance the meter stick. (See Figure Six below.) Record on the data sheet, the location of this balancing mass, x_2 , **measured from the pivot**, and the total mass, M_2 , you have hanging at this location.

Figure Six

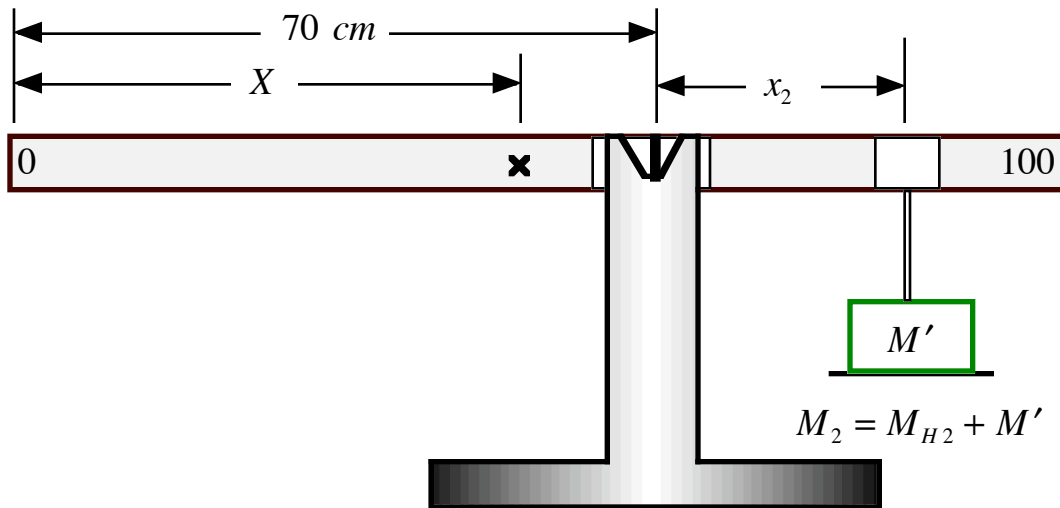

Free-Body Diagram

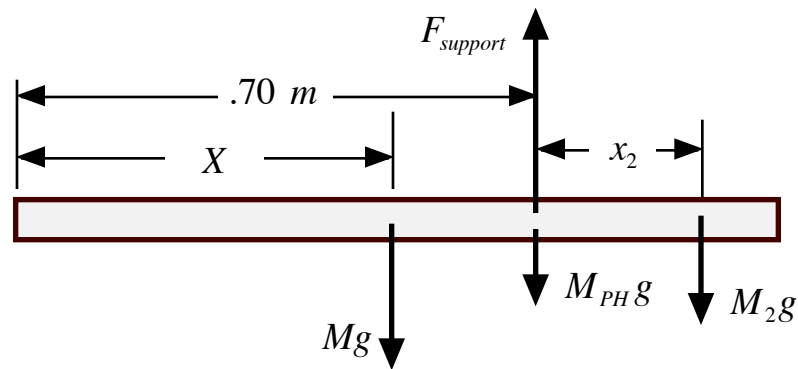

Analysis of the Two Simultaneous Equations in X and M

Equating the magnitudes of the counterclockwise and clockwise torques about the pivot located at the 60 cm mark, we have

$$[0.60\text{ m} - X]Mg = x_1 M_1 g \quad (6)$$

Equating the magnitudes of the counterclockwise and clockwise torques about the pivot located at the 70 cm mark, we have

$$[0.70\text{ m} - X]Mg = x_2 M_2 g \quad (7)$$

If we solve equation (6) for X , we find

$$X = [0.60 \text{ m}] - \frac{x_1 M_1 g}{Mg} = [0.60 \text{ m}] - x_1 \left(\frac{M_1}{M} \right) . \quad (8)$$

Substitution of equation (8) into (7) gives us

$$Mg \left\{ 0.70 \text{ m} - \left[[0.60 \text{ m}] - x_1 \left(\frac{M_1}{M} \right) \right] \right\} = x_2 M_2 g , \quad (9)$$

and

$$Mg[0.70 \text{ m} - 0.60 \text{ m}] + x_1 \left(\frac{M_1}{M} \right) Mg = x_2 M_2 g , \quad (10)$$

The mass M , then, is given by

$$M = \frac{x_2 M_2 - x_1 M_1}{(0.10 \text{ m})} . \quad (11)$$

We can now use equation (11) in equation (8) to find X .

Data Sheet

The Masses of the "Players":

$$M_S = \underline{\hspace{2cm}} \text{ kg}$$

$$M_{PH} = \underline{\hspace{2cm}} \text{ kg}$$

$$M_{H1} = \underline{\hspace{2cm}} \text{ kg}$$

$$M_{H2} = \underline{\hspace{2cm}} \text{ kg}$$

The Center of Mass of the Meter Stick:

$$X_{CM} = \underline{\hspace{2cm}} \text{ m}$$

A Rotational Equilibrium Exercise:

$$r_{\perp,1} = \underline{\hspace{2cm}} \text{ m}$$

$$M_1 = \underline{\hspace{2cm}} \text{ kg}$$

$$r_{\perp,2} = \underline{\hspace{2cm}} \text{ m}$$

$$M_2 = \underline{\hspace{2cm}} \text{ kg}$$

$$\Gamma_{CCW} = r_{\perp,1} M_1 g = \underline{\hspace{2cm}} \text{ mN}$$

$$\Gamma_{CW} = r_{\perp,2} M_2 g = \underline{\hspace{2cm}} \text{ mN}$$

$$\% \text{Diff between } \Gamma_{CCW} \text{ and } \Gamma_{CW} = \underline{\hspace{2cm}}$$

A Second Rotational Equilibrium Exercise:

$$r_{\perp,1} = \underline{\hspace{2cm}} \text{ m}$$

$$M_1 = \underline{\hspace{2cm}} \text{ kg}$$

$$r_{\perp,2} = \underline{\hspace{2cm}} \text{ m}$$

$$M_2 = \underline{\hspace{2cm}} \text{ kg}$$

$$\Gamma_{CCW} = r_{\perp,1} M_1 g = \underline{\hspace{2cm}} \text{ mN}$$

$$\Gamma_{CW} = r_{\perp,2} M_2 g = \underline{\hspace{2cm}} \text{ mN}$$

$$\% \text{Diff between } \Gamma_{CCW} \text{ and } \Gamma_{CW} = \underline{\hspace{2cm}}$$

PHY2053 LABORATORY

Experiment Nine

The Moment of Inertia

THEORY

Newton's first law states that an object at rest--or moving with constant velocity--will continue at rest--or to move with constant velocity--unless acted on by a net, external force. One can think of the mass of a physical thing as a "measure" of that thing's "resistance" to a change in its linear momentum. Physical things also "resist" a change in their angular momentum. The physical quantity we use to "measure" this resistance to a change in rotation is called the **moment of inertia**. The moment of inertia is the rotational analog to the mass.

The moment of inertia of a physical thing depends on two factors. First, the moment of inertia depends on the amount of mass. Second, the moment of inertia depends on the way this mass is "smeared" in space, the shape of the mass, if you will. The most important fact about the shape is how far the mass is from the axis of rotation. The further the mass is from the axis of rotation, the greater its "resistance" to any change in rotation about that axis.

In Figure One below, we have represented an arbitrarily shaped physical thing of total mass M and an axis which passes through the center of mass of the physical thing. Also represented is an "itty-bitty" part of the total mass, dM . This "itty-bitty" mass has only an "itty-bitty" moment of inertia, dI . That "itty-bitty" moment of inertia is defined by

$$dI = r_{\perp}^2 dM , \quad (1)$$

where r_{\perp} is the perpendicular distance of the "itty-bitty" mass from the axis of rotation.

To find the total moment of inertia, we must add up all of the "itty-bitty" contributions. We have, then,

$$I = \int dI = \int r_{\perp}^2 dM . \quad (2)$$

In general, the mathematical solution for equation (2) is very difficult--if not impossible--unless the physical thing is symmetrically "smeared" about the axis of rotation.

Figure One

The Moment of Inertia of an "Itty-bitty" Mass About an Axis Passing Through the Center of Mass

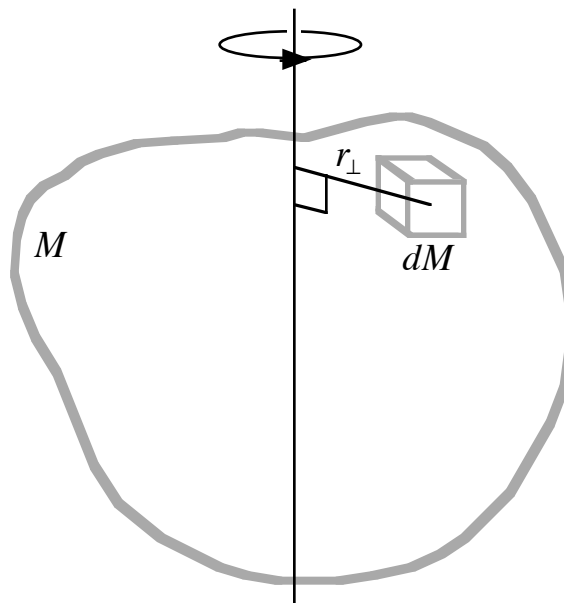

If we wish to know the moment of inertia of the physical thing about an axis that does not pass through the center of mass, we can use the so-called **parallel axis theorem**, as represented in Figure Two below. First, we must calculate the moment of inertia with respect to a parallel axis that does pass through the center of mass, I_{cm} . The total moment of inertia is then given by

$$I = I_{cm} + Md^2, \quad (3)$$

where d is the perpendicular distance between the parallel axes.

Figure Two

**The Moment of Inertia of a Physical Thing
About a Parallel Axis Not Passing Through the Center of Mass**

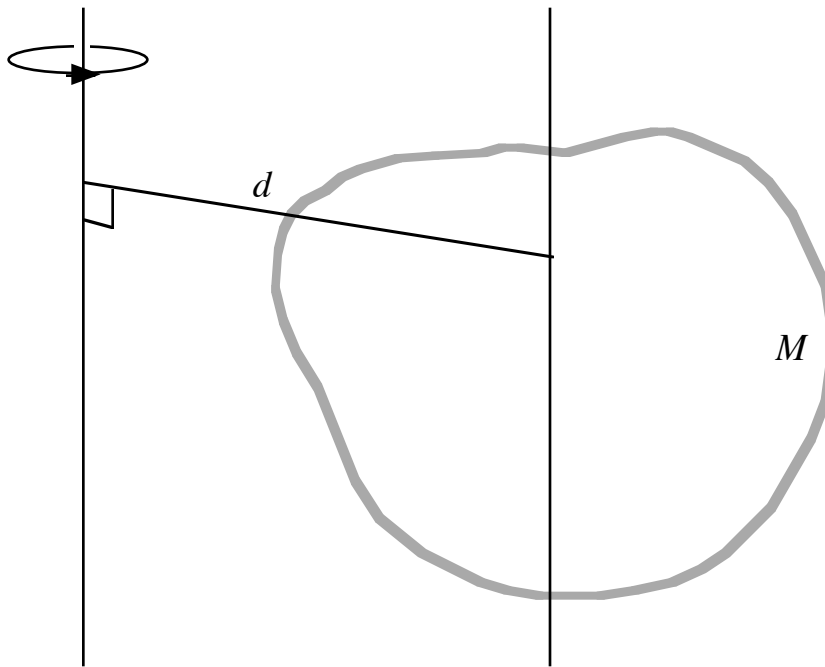

Since the calculations of asymmetrical objects can be virtually impossible to perform, it would be helpful to design an **empirical process** that allows us to “measure” the moment of inertia. To that end, consider the situation represented in Figure Three below. A thin circular disk of radius R and mass M_D is free to rotate about a horizontal axle **with friction**. A massless, inextensible string is wrapped around the rim of the disk. Attached to one end of the string is a hanging mass M . The hanging mass is released from rest, and after a time interval Δt , it has moved through a vertical distance ℓ . We wish to use these measurable quantities to determine the moment of inertia of the disk. (We assume there is no slipping between the rim of the disk and the string.)

A force analysis of the hanging mass and the disk is shown below in Figure Four. Summing the forces acting on the hanging mass we have

$$Mg - T = Ma. \quad (4)$$

and, therefore,

$$T = Mg - Ma. \quad (5)$$

Summing the torques with respect to the axis of rotation of the wheel, we have

$$\Gamma_T - \Gamma_f = I\alpha = I(a/R), \quad (6)$$

Figure Three
“Measuring” the Moment of Inertia

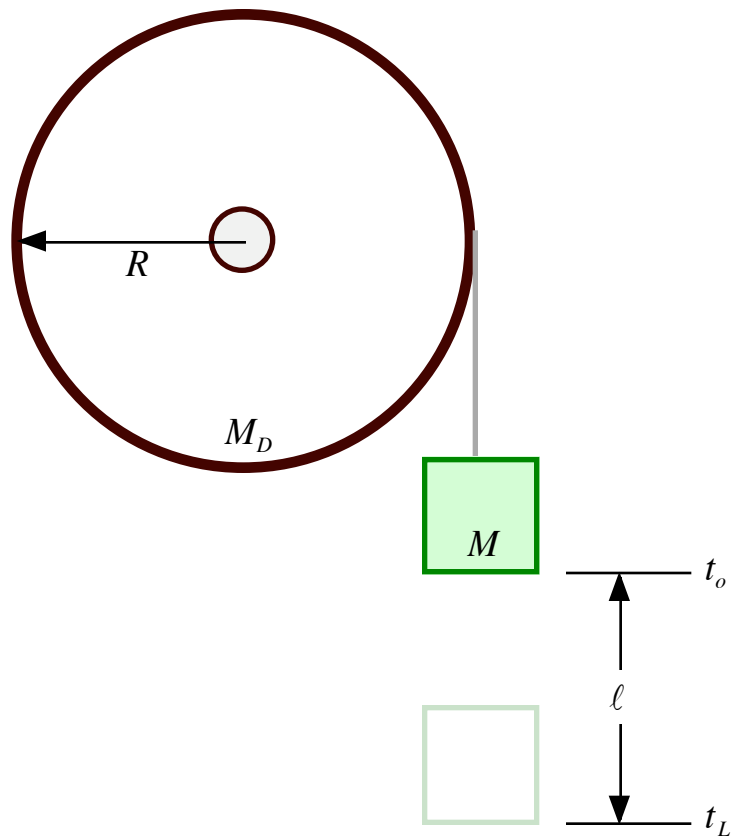
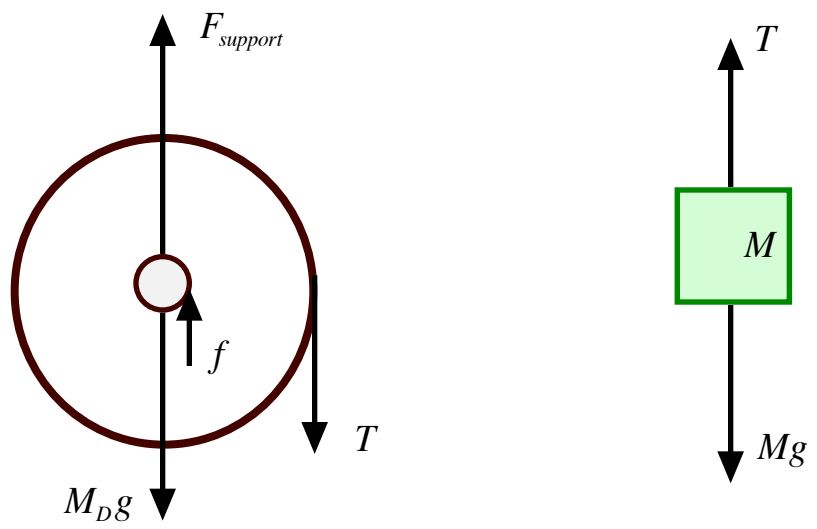

Figure Four
Free-Body Diagram



where we have used the fact that no slipping means that the angular acceleration is related to the linear acceleration by

$$\alpha = a / R . \quad (7)$$

Equation (6) implies

$$I = \frac{R}{a} [\Gamma_T - \Gamma_f] . \quad (8)$$

The torque due to the tension in the string is given by

$$\Gamma_T = RT = R(Mg - Ma) . \quad (9)$$

To estimate the frictional torque, we find the amount of mass needed to get the wheel to rotate. We should be able to put some amount of mass on the wheel and not disturb the rotational equilibrium. At some mass M_f , however, the wheel should begin to rotate. So, we have

$$\Gamma_f - RM_f g = I\alpha = 0 , \quad (10)$$

and

$$\Gamma_f = RM_f g . \quad (11)$$

Substitution of equation (9) into (11) into equation (8) gives us

$$I = \frac{R}{a} [R(Mg - Ma) - RM_f g] = \frac{R^2}{a} [Mg - Ma - M_f g] . \quad (12)$$

Factoring out the hanging mass value M , equation (12) becomes

$$I = \frac{MR^2}{a} \left[g - a - \frac{M_f}{M} g \right] . \quad (13)$$

Distributing the a and simplifying equation (13) we get

$$I = MR^2 \left[\frac{g}{a} - 1 - \frac{M_f}{M} \frac{g}{a} \right] = MR^2 \left[\frac{g}{a} \left(1 - \frac{M_f}{M} \right) - 1 \right] . \quad (14)$$

As all of these quantities are measurable, we can use this process to “measure” moments of inertia.

In this experiment, we will also make use of the parallel axis theorem. We will be placing four identical cylindrical masses of diameter D equidistant from the center of a circular wheel. The moment of inertia of this configuration is given by

$$I_{cy, tot} = 4M_{cy} [d^2 + (1/8) D^2] . \quad (15)$$

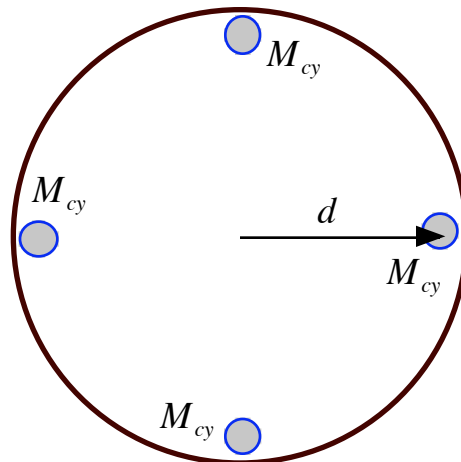

PHY2053 LABORATORY

Experiment Nine

The Moment of Inertia

Name:

Date:

Day and Time:

EQUIPMENT NEEDED

One One-meter Stick
One Rotodyne Box of “Stuff”
One Table Vise
One Two-way Clamp (Large)

One Rotodyne Wheel
One Stopwatch
One Aluminum Rod (Thick)

PROCEDURE

Figure Five

*Rotodyne Wheel
(Front)*

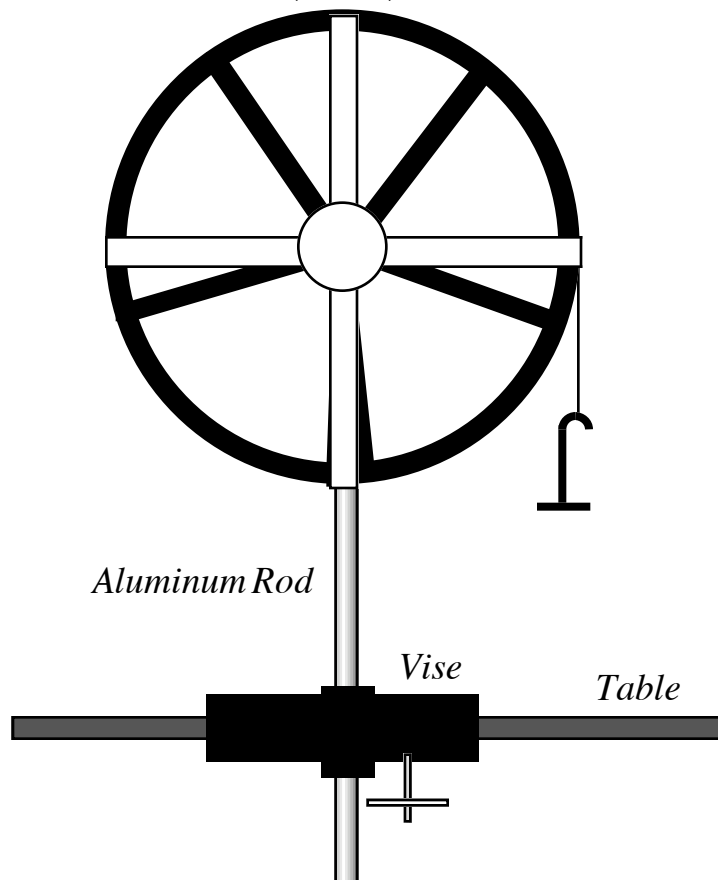

Setting up the Rotodyne Wheel

1.) The mass of the Rotodyne wheel is

$$M_{RD} = 1.41 \pm .05 \text{ kg},$$

and its effective radius is

$$R_{RD} = 0.200 \text{ m} \pm 0.005 \text{ m}.$$

2.) Secure the vise to the front edge of your lab table. Secure the aluminum rod to the vise. About three-quarters of the way up the aluminum rod, secure the large two-way clamp. Attach the axle extension to the **back** of the Rotodyne wheel. (The front of the wheel is where the platform and mounting holes are located.) Secure the axle and wheel to the large two-way clamp trying to get the wheel axle horizontal.

Measuring the Frictional Mass

3.) There should be nylon string wrapped around the rim of the wheel. Tie *5 grams* of mass to the free end of the nylon string. If this does not cause the wheel to rotate, **add** more mass until you find an amount of mass that does. Record the value, M_f , on the data sheet. If the five *grams* does make the wheel rotate, take mass off until you have a mass that does not rotate the wheel. Record this value on the data sheet. (At less than five *grams*, we do not have much friction.)

Measuring the Moment of Inertia of the Rotodyne Wheel Itself

4.) Take the large mass pan out of the your box of goodies. Put the pan on the scale to measure its mass. Record this value on the data sheet. Attach the pan to the string on the wheel. Place an additional *50 grams* on the pan. Do a test run by releasing the pan from rest. The system should **accelerate smoothly** downward and, thereby, rotationally accelerate the wheel. You need to be able to perform this process consistently. Also, you must determine a fixed vertical distance ℓ **from the floor to the bottom of the pan** at that point from which it is to be released. (I recommend one *meter*.) Record the value of ℓ on the data sheet. Do a few more test runs and use the stopwatch to time the pan from release to the instant it strikes the floor. It is advisable to put something “soft” on the floor, under the pan, to cushion it when it strikes the floor.

5.) Do five official runs and record your times on the data sheet.

6.) Average your five times and record this value on the data sheet.

7.) Calculate the acceleration of the pan using equation.

8.) Calculate, “measure”, the moment of inertia I_{RD} of the Rotodyne wheel.

9.) The manufacturer of the Rotodyne Wheel states that the radius of gyration of the wheel is

$$R_g = 0.14 \text{ m} \pm 0.01 \text{ m} .$$

A point mass equal in value to the mass of the entire wheel would have to be located a distance R_g from the axis of rotation to have the same moment of inertia as the entire wheel itself. This gives us the moment of inertia of the wheel itself according to the company that manufactures the wheel. We would have

$$\begin{aligned} I_{RD, \text{man}} &= M_{RD} R_g^2 = [(1.41 \pm .05) \text{ kg}][(0.14 \pm .01) \text{ m}]^2 \\ &= [0.028 \pm .005] \text{ kg m}^2 . \end{aligned} \tag{16}$$

10.) Calculate the % difference between your measure of the moment of inertia and that specified by the manufacturing company. Recall,

$$\% \text{Difference} \equiv \left| \frac{N_1 - N_2}{N_1 + N_2} \right| \times 200\% . \tag{17}$$

*Measuring the Moment of Inertia of the Wheel with Four Cylindrical Masses In
(Configuration One)*

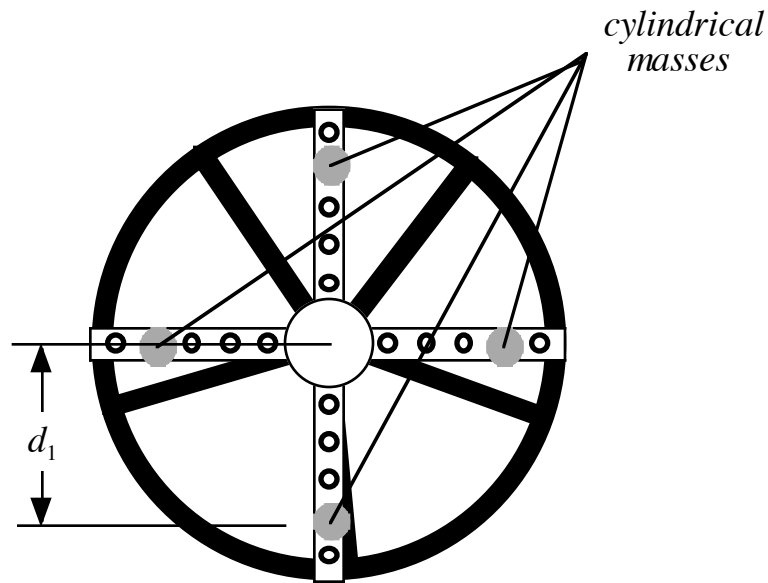

- 11.) Screw the four 250 gram cylindrical masses into the four holes **one in** from those furthest from the hub of the wheel. Measure the distance from the center of the wheel to the center of the hole the cylindrical mass is in. Record this value, d_1 , on the data sheet. Measure the diameter of the cylinder, D_{cy} , and record the value on the data sheet.
- 12.) Do five official runs and record your times on the data sheet. (Use the same mass M as before.)
- 13.) Average your five times and record this value on the data sheet.
- 14.) Calculate the acceleration of the pan using equation.
- 15.) Calculate the moment of inertia of the four cylindrical masses.
- 16.) Calculate the moment of inertia of the system in configuration one.
- 17.) Calculate the %Difference between your calculation of the moment of inertia of the four cylinders and that measured by the moment of inertia of configuration one.

*Measuring the Moment of Inertia of the Wheel with Four Cylindrical Masses In
(Configuration Two)*

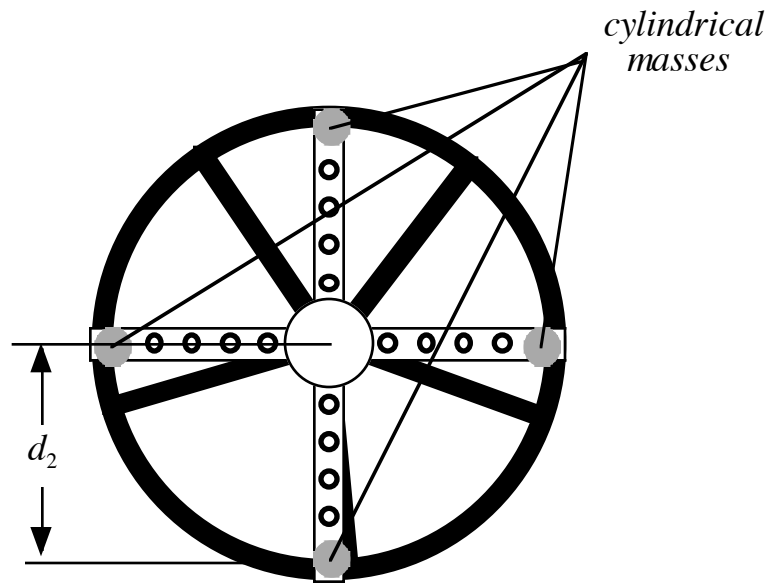

- 18.) Screw the four 250 gram cylindrical masses into the four holes furthest from the hub of the wheel. Measure the distance from the center of the wheel to the center of the hole the cylindrical mass is in. Record this value, d_2 , on the data sheet.
- 19.) Do five official runs and record your times on the data sheet. (Use the same mass M as before.)
- 20.) Average your five times and record this value on the data sheet.
- 21.) Calculate the acceleration of the pan using equation.
- 22.) Calculate the moment of inertia of the four cylindrical masses.
- 23.) Calculate the moment of inertia of the system in configuration two.
- 24.) Calculate the %Difference between your calculation of the moment of inertia of the four cylinders and that measured by the moment of inertia of configuration two.

Data Sheet

Rotodyne Wheel Specifications

$$I_{RD,man} = [0.028 \pm .005] \text{ kg } m^2$$

$$R = 0.200 \text{ m } \pm 0.005 \text{ m}$$

Measuring the Frictional Mass

$$M_f = \text{_____ kg}$$

Measuring the Moment of Inertia of the Rotodyne Wheel

$$M_{pan} = \text{_____ kg}$$

$$M = M_{pan} + M_{added} = \text{_____ kg}$$

$$M_f / M = \text{_____}$$

$$\ell = \text{_____ m}$$

$$t_{ave} = \text{_____ s}$$

$$a = \frac{2\ell}{t^2} = \text{_____ } \frac{m}{s^2}$$

$$I_{RD} = MR^2 \left[\frac{g}{a} \left(1 - \frac{M_f}{M} \right) - 1 \right] = \text{_____ } \text{kg } m^2$$

Trial #	Time Values (s)
1	
2	
3	
4	
5	

$$\% \text{Difference between } I_{RD} \text{ and } I_{RD,man} = \text{_____}$$

**Measuring the Moment of Inertia of the Wheel with Four Cylindrical Masses
(Configuration One)**

$$I_{RD} = \text{_____} \text{ kg m}^2$$

$$d_1 = \text{_____} \text{ m}$$

$$D = \text{_____} \text{ m}$$

$$I_{\text{cy1, cal}} = 4 M_{\text{cy}} \left[d_1^2 + (1/8) D^2 \right] = \text{_____} \text{ kg m}^2$$

$$t_{\text{ave}} = \text{_____} \text{ s}$$

$$a = \frac{2\ell}{t^2} = \text{_____} \frac{\text{m}}{\text{s}^2}$$

$$I_{\text{conf1}} = MR^2 \left[\frac{g}{a} \left(1 - \frac{M_f}{M} \right) - 1 \right] = \text{_____} \text{ kg m}^2$$

$$I_{\text{cy1, meas}} = I_{\text{conf1}} - I_{RD} = \text{_____} \text{ kg m}^2$$

<i>Trial #</i>	<i>Time Values (s)</i>
1	
2	
3	
4	
5	

% Difference between $I_{\text{cy1, meas}}$ and $I_{\text{cy1, cal}} = \text{_____}$

**Measuring the Moment of Inertia of the Wheel with Four Cylindrical Masses
(Configuration Two)**

$$I_{RD} = \underline{\hspace{4cm}} \text{ kg m}^2$$

$$d_2 = \underline{\hspace{4cm}} \text{ m}$$

$$D = \underline{\hspace{4cm}} \text{ m}$$

$$I_{cy2,cal} = 4M_{cy} [d_2^2 + (1/8)D^2] = \underline{\hspace{4cm}} \text{ kg m}^2$$

$$t_{ave} = \underline{\hspace{4cm}} \text{ s}$$

$$a = \frac{2\ell}{t^2} = \underline{\hspace{4cm}} \frac{\text{m}}{\text{s}^2}$$

$$I_{conf2} = MR^2 \left[\frac{g}{a} \left(1 - \frac{M_f}{M} \right) - 1 \right] = \underline{\hspace{4cm}} \text{ kg m}^2$$

$$I_{cy2,meas} = I_{conf2} - I_{RD} = \underline{\hspace{4cm}} \text{ kg m}^2$$

<i>Trial #</i>	<i>Time Values (s)</i>
1	
2	
3	
4	
5	

%Difference between $I_{cy2,meas}$ and $I_{cy2,cal} = \underline{\hspace{4cm}}$

PHY2053 LABORATORY

Experiment Ten

The Period of a Physical Pendulum

THEORY:

The Period of a Physical Pendulum

An arbitrarily shaped physical thing of mass M is free to rotate about a frictionless, horizontal axle, as represented below in Figure One. The net torque exerted on the object by the gravitational force--we ignore frictional effects--is given by

$$\begin{aligned} \vec{T}_{net} &= \vec{r} \times \vec{F}^G = (r \hat{r}) \times (-Mg \hat{j}) = rMg (\hat{r} \times -\hat{j}) = rMg (-\hat{k}) \\ &= -rMg \sin \varphi \hat{k} . \end{aligned} \tag{1}$$

So, we can now write

$$I\alpha = -rMg \sin \varphi , \tag{2}$$

and

$$\alpha = \frac{d\omega}{dt} = \frac{d}{dt} \left[\frac{d\varphi}{dt} \right] = \lim_{\Delta t \rightarrow 0} \frac{\Delta\omega}{\Delta t} = \lim_{\Delta t \rightarrow 0} \left[\lim_{\Delta t \rightarrow 0} \frac{\Delta\varphi}{\Delta t} \right] = - \left[\frac{rMg}{I} \right] \sin \varphi . \tag{3}$$

Figure One
A Physical Pendulum

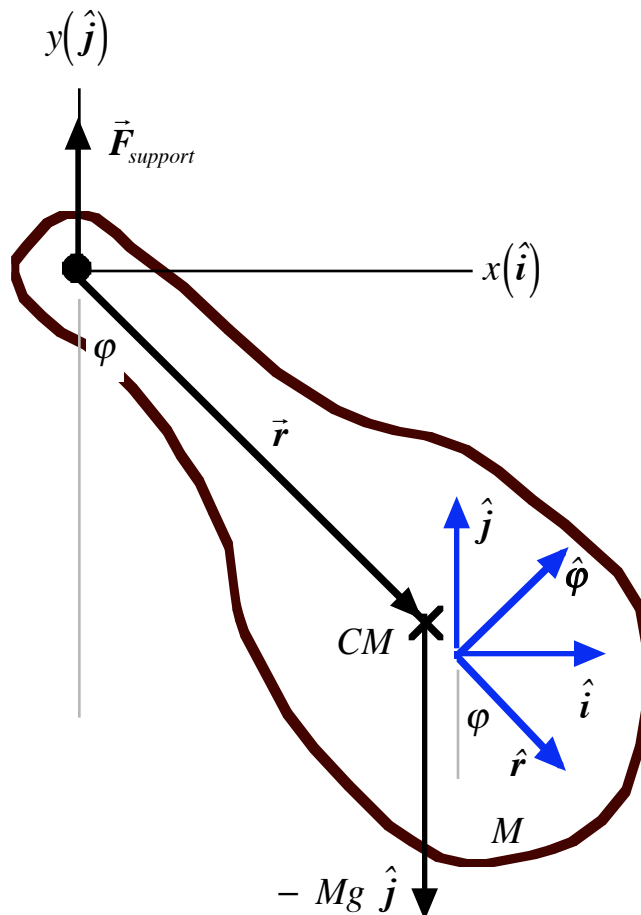

We have seen an equation like (3) before, in the experiment on the simple pendulum and the ballistic pendulum. We are going to use the same kind of an analysis. We first begin with the so-called **small angle approximation**. Recall that if φ_o is small and measured in *radians*, then we have

$$\sin \varphi \approx \varphi , \quad (4)$$

and equation (3) becomes

$$\alpha = \frac{d^2 \varphi}{dt^2} = - \left[\frac{rMg}{I} \right] \varphi . \quad (5)$$

We assume a solution of the form

$$\varphi = \varphi_o \cos(\omega' t) , \quad (6)$$

where ω' is a constant called the angular frequency and not to be confused with the instantaneous angular speed ω . For the parameters given, ω' turns out to be

$$\omega' = 2\pi f = \frac{2\pi}{\tau} = \sqrt{\frac{rMg}{I}} , \quad (7)$$

and, therefore,

$$\omega'^2 = \frac{rMg}{I} = (2\pi f)^2 = \left(\frac{2\pi}{\tau} \right)^2 , \quad (8)$$

so that,

$$\sqrt{\frac{rMg}{I}} = \frac{2\pi}{\tau} . \quad (9)$$

So, theory suggests that the time needed for one oscillation of our system is given by

$$\tau = 2\pi \sqrt{\frac{I}{rMg}} . \quad (10)$$

Recall that M is the mass of the system, I the moment of inertia of the system, r is the distance to the center of mass from the axis of rotation, and g indicates the pendulum is on the Earth.

The only constraint is that the system be released from rest at a small angle φ_o measured from the vertical. Now, we want to **experimentally test equation (10)** using a thin rod.

The Moment of Inertia of a Uniformly Thin Rod

A uniformly thin rod of mass M and length ℓ is free to rotate about a horizontal axis perpendicular to the rod at a point a distance d from one end of the rod, as represented below in Figure Two. (If you do not understand calculus, skip to equation (16)!) The moment of inertia is defined by

$$I = \int r_{\perp}^2 dm . \quad (11)$$

To solve this integral, we note

$$r_{\perp} = x' , \quad (12)$$

$$dm = \lambda dx' , \quad (13)$$

where the **linear mass density** λ is defined by

$$\lambda = \frac{M}{\ell} . \quad (14)$$

Substitution of equations (12) through (14) into equation (11) gives us

$$\begin{aligned} I_{rod} &= \frac{M}{\ell} \int_{-d}^{\ell-d} x'^2 dx' \\ &= \frac{M}{3\ell} [x'^3] \Big|_{-d}^{\ell-d} = \frac{M}{3\ell} [(\ell-d)^3 - (-d)^3] \\ &= \frac{M}{3\ell} [\ell^3 - 3\ell^2 d + 3\ell d^2 - d^3 + d^3] = \frac{M}{3\ell} [\ell^3 - 3\ell^2 d + 3\ell d^2] . \end{aligned} \quad (15)$$

We can rearrange this last equation to

$$I_{rod} = \frac{M}{3\ell} \left[\ell^3 \left(1 - 3\frac{d}{\ell} + 3\frac{d^2}{\ell^2} \right) \right] = \frac{1}{3} M \ell^2 \left[1 - 3\frac{d}{\ell} \left(1 - \frac{d}{\ell} \right) \right] . \quad (16)$$

Now, I wish to define a new parameter C by

$$C = \frac{d}{\ell} . \quad (17)$$

With this parameter, we can rewrite equation (16) as

$$I_{rod} = \frac{M}{3\ell} \left[\ell^3 (1 - 3C + 3C^2) \right] = \frac{1}{3} M \ell^2 [1 - 3C(1 - C)] . \quad (18)$$

Figure Two
The Moment of Inertia of a Uniformly Thin Rod without Holes

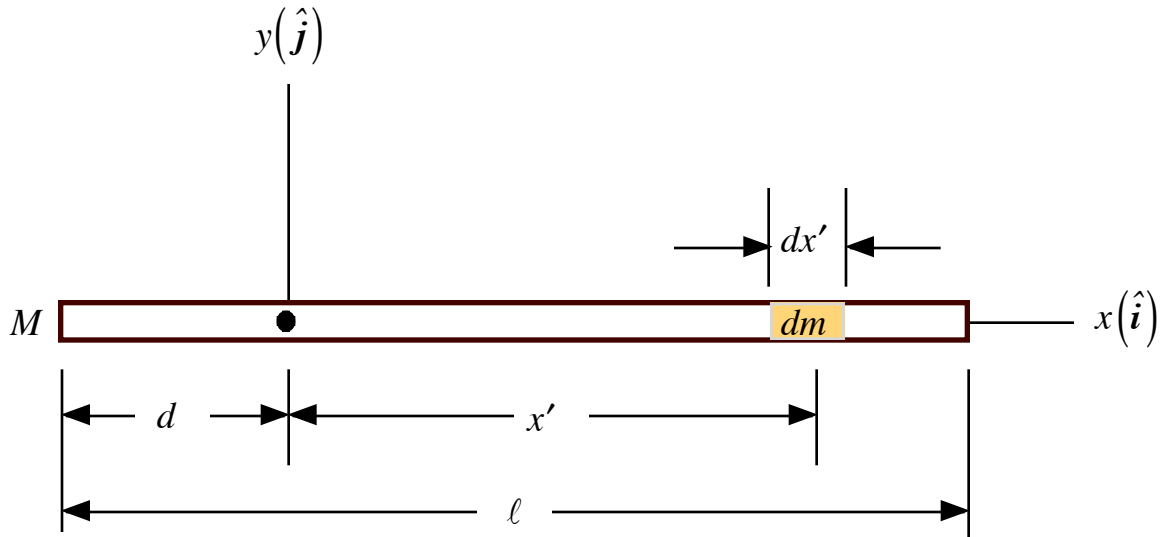

There are two special cases of interest. Note that if $d = 0$, then $C = 0$ and equation (18) reduces to

$$I_{rod,end} = \left(\frac{1}{3} \right) M \ell^2 . \quad (19)$$

Also, if $d = \ell / 2$, then $C = 1 / 2$ and equation (18) becomes

$$I_{rod,center} = \frac{1}{3} M \ell^2 [1 - 3(1/2)(1 - (1/2))] = \frac{1}{3} M \ell^2 [1 - (3/4)] = (1/12) M \ell^2 . \quad (20)$$

Our analysis of the thin rod has assumed that it is made of a homogeneous material with **no holes** in it. The thin rod that we will use to do this experiment does have some holes in it. We are going to ignore the very small error that this will introduce into our analysis.

In Figure Three below, we have a pictorial representation of the thin rod we will use in our experiment. The rod has five holes. The first hole is the axle hole. The remaining holes we number from one to four moving from left to right. The last four holes are for attaching cylindrical masses to the thin rod.

Figure Three

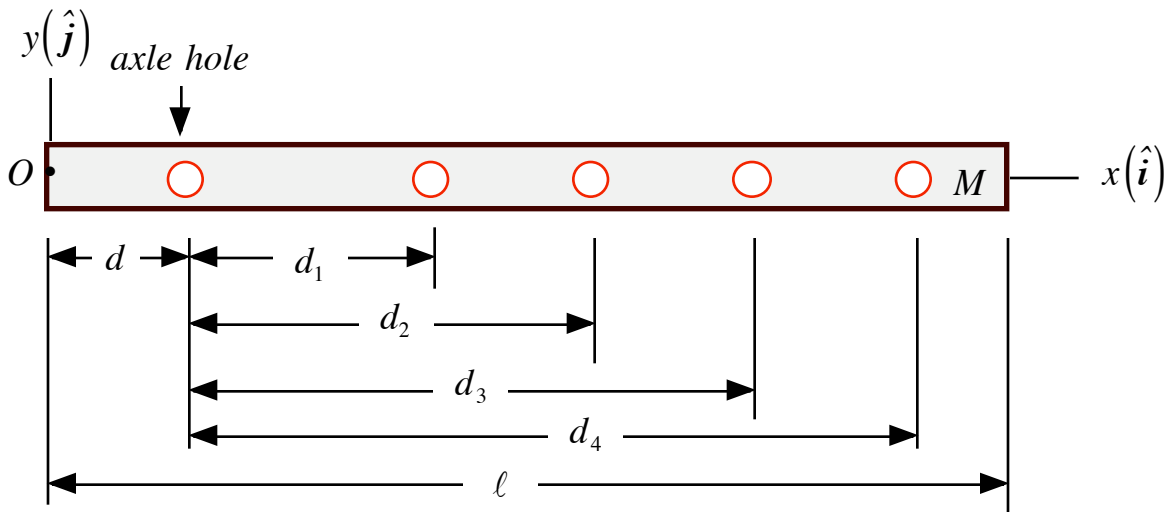

PHY2053 LABORATORY

Experiment Ten

The Period of a Physical Pendulum

Name:

Date:

Day and Time:

EQUIPMENT NEEDED

One One-meter Stick
 One Stopwatch
 One Aluminum Pole
 One old 50 gram Mass Pan (For Axle)
 One Physical Pendulum (Thin Rod)

One Rotodyne Box of “Stuff”
 One Table Vise
 One Two-way Clamp (Large)
 One Vernier Caliper

PROCEDURE

Measuring Masses, Lengths and Centers of Mass

- 1.) Measure the mass of the rod by itself, M_{rod} , and record this value on the data sheet.
- 2.) Choose and identify one screw-on cylinder and measure its mass, M_{cyl} and record its value on the data sheet. Using the vernier calipers, measure the diameter of cylinder one, D_{cyl1} , and record this value below on the data sheet.
- 3.) Choose and identify a second screw-on cylinder and measure its mass M_{cyl2} , and record its value on the data sheet. Using the vernier calipers, measure the diameter of cylinder two, D_{cyl2} , and record this value on the data sheet.

The Rod Itself

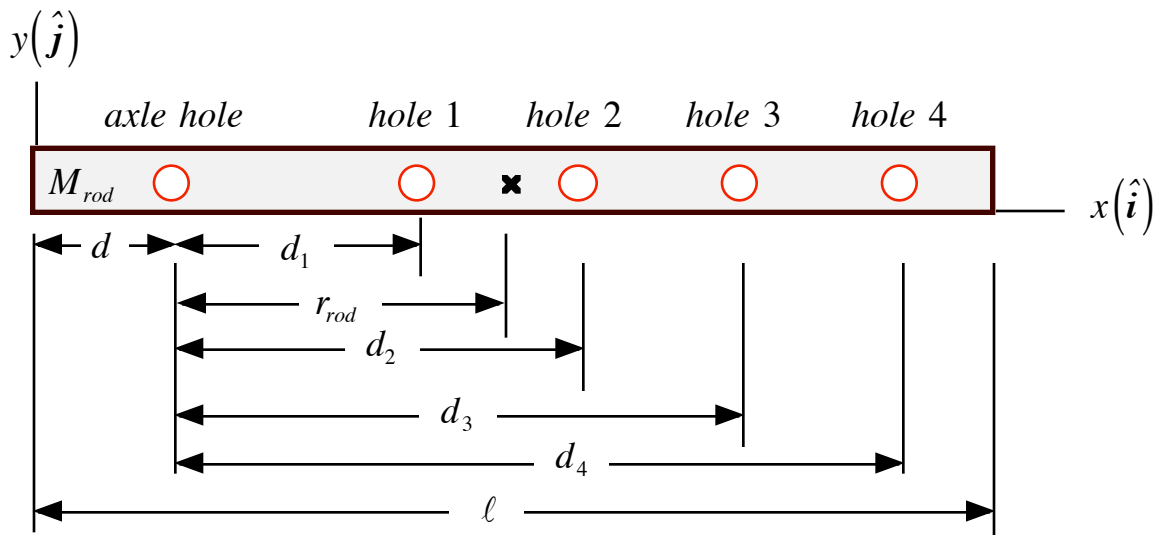

- 4.) Using the diagram above, measure the following lengths and record their values on the data sheet: d , l , d_3 , d_4 .
- 5.) Calculate and record the following ratio: $C = \frac{d}{l}$.
- 6.) Balance the rod on the edge of a meter stick to determine the center of mass of the rod by itself. Measure the distance from the axle to the center of mass of the rod, r_{rod} , and record this value on the data sheet.

Configuration One

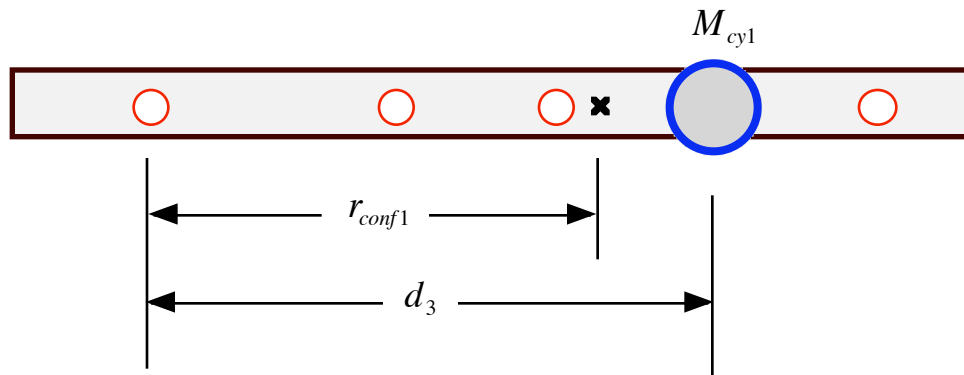

7.) Screw cylindrical mass one into hole three. Balance this configuration--configuration one--on the edge of a meter stick to determine the location of the center of mass of configuration one. Measure the distance from the axle to the center of mass of configuration one, r_{conf1} , and record the value on the data sheet.

Configuration Two

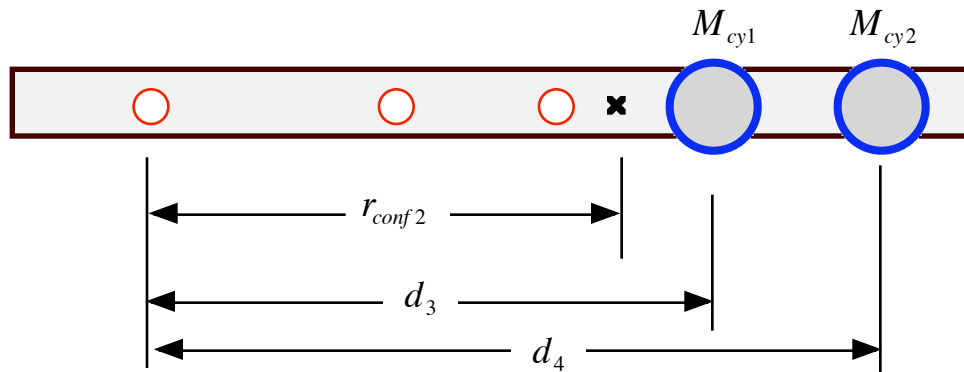

8.) Screw cylindrical mass two into hole four. Balance this configuration--configuration two--on the edge of a meter stick to determine the location of the center of mass of configuration two. Measure the distance from the axle to the center of mass of configuration two, r_{conf2} , and record the value on the data sheet.

Calculating Periods

The Calculated Period of the Rod Itself

9) We now have enough information to calculate what the theory suggests the period of oscillation should be. First, we must calculate the moment of inertia of the rod itself. Using your values for C , M_{rod} and ℓ , calculate the moment of inertia of the rod and record the value on the data sheet.

$$I_{rod} = \frac{1}{3} M_{rod} \ell^2 [1 - 3C(1 - C)] .$$

10.) Calculate the theoretical prediction of the period of the rod and record the value on the data sheet.

$$\tau_{rod, theory} = 2\pi \sqrt{\frac{I_{rod}}{r_{rod} M_{rod} g}} .$$

The Calculated Period of Configuration One

11.) Cylindrical mass one screwed into hole three should have a moment of inertia given by

$$I_{cy1} = M_{cy1} \left[d_3^2 + \frac{1}{8} D_{cy1}^2 \right] .$$

Calculate the moment of inertia of cylinder one and record this value on the data sheet below.

12.) The total moment of inertia of configuration one is given by

$$I_{conf1} = I_{rod} + I_{cy1} .$$

Calculate the total moment of inertia of configuration one and record this value on the data sheet.

13.) The total mass of configuration one is given by

$$M_{conf1} = M_{rod} + M_{cy1} .$$

Calculate the total mass of configuration one and record the value on the data sheet.

14.) Calculate the theoretical prediction of the period of configuration one and record this value on the data sheet.

$$\tau_{conf1, theory} = 2\pi \sqrt{\frac{I_{conf1}}{r_{conf1} M_{conf1} g}} .$$

The Calculated Period of Configuration Two

15.) Cylindrical mass two screwed into hole four should have a moment of inertia given by

$$I_{cy2} = M_{cy2} \left[d_4^2 + \frac{1}{8} D_{cy2}^2 \right] .$$

Calculate the moment of inertia of cylinder two and record this value on the data sheet below.

16.) The total moment of inertia of configuration two is given by

$$I_{conf2} = I_{conf1} + I_{cy2} .$$

Calculate the total moment of inertia of configuration two and record this value on the data sheet.

17.) The total mass of configuration two is given by

$$M_{conf2} = M_{conf1} + M_{cy2} .$$

Calculate the total mass of configuration two and record the value on the data sheet.

18.) Calculate the theoretical prediction of the period of configuration two and record this value on the data sheet.

$$\tau_{conf2, theory} = 2\pi \sqrt{\frac{I_{conf2}}{r_{conf2} M_{conf2} g}} .$$

Measuring the Periods of Oscillation

Measuring the Period of the Rod Itself

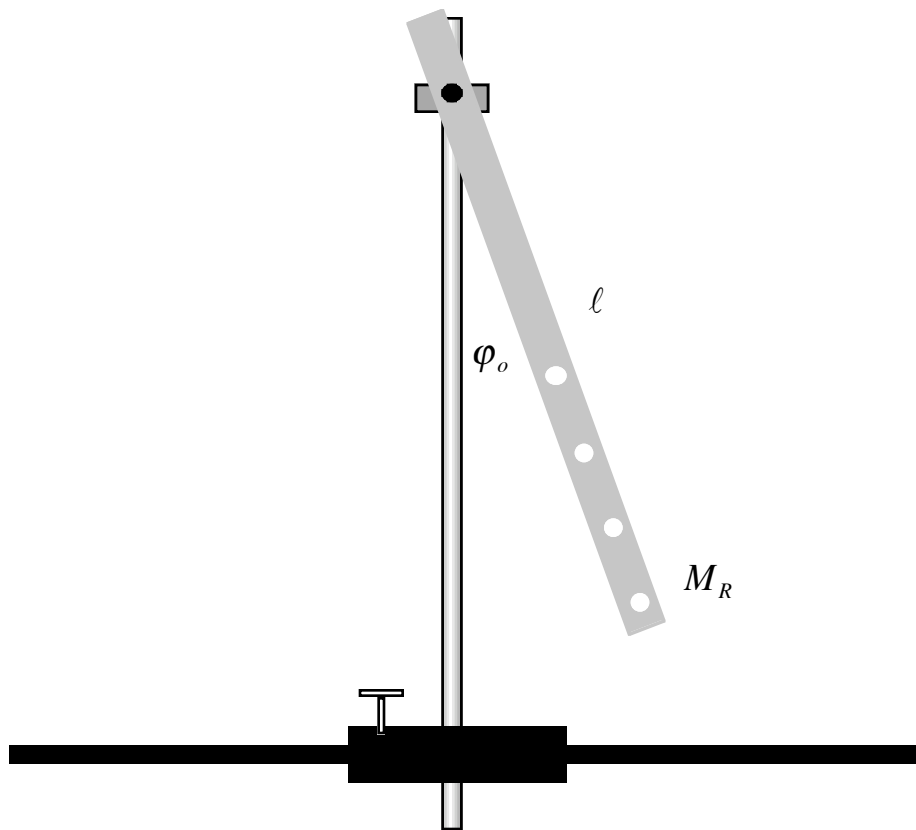

19.) Using the diagram above, set up the apparatus as shown. Attach the vise securely to the table. Secure the aluminum pole to the vise. Using an old mass pan as the axle, attach the thin rod to the mass pan and both of these, using a clamp, to the aluminum pole. **For safety, Never leave the end of the axle exposed! Attach the pan to cover the end! An exposed axle represents a real danger if you were to accidentally run into it!**

20.) Pull the thin rod to the side until the starting angle is approximately fifteen *degrees*; i.e. $\varphi_o \approx 15^\circ$. Release the rod from rest and **start** your stopwatch and **count zero** when the rod passes the vertical moving to the left. When it next passes the vertical moving to the left, count one. Do this until it has made exactly **five complete oscillations**, stopping the watch on the count of five. Divide the total elapsed time by five and record this value on the data sheet as your first time trial. Repeat step 20.) four more times and determine the average value $\tau_{rod, measured}$ for the period of the rod.

21.) Calculate the percent difference between $\tau_{rod, theory}$ and $\tau_{rod, measured}$.

Measuring the Period of Configuration One

22.) Take cylindrical mass one and screw it into hole three. Pull the system to the side until the starting angle is approximately fifteen *degrees*; i.e. $\varphi_o \approx 15^\circ$. Release the rod from rest and **start** your stopwatch and **count zero** when the rod passes the vertical moving to the left. When it next passes the vertical moving to the left, count one. Do this until it has made exactly **five complete**

oscillations, stopping the watch on the count of five. Divide the total elapsed time by five and record this value on the data sheet below as your first time trial. Repeat step 22.) four more times and determine the average value $\tau_{conf 1, measured}$ for the period of the rod.

23.) Calculate the percent difference between $\tau_{conf 1, theory}$ and $\tau_{conf 1, measured}$.

Measuring the Period of Configuration Two

Calculating the Period of the Thin Rod in Configuration Two

24.) Take cylindrical mass two and screw it into hole four. Pull the system to the side until the starting angle is approximately fifteen *degrees*; i.e. $\varphi_o \approx 15^\circ$. Release the rod from rest and **start** your stopwatch and **count zero** when the rod passes the vertical moving to the left. When it next passes the vertical moving to the left, count one. Do this until it has made exactly **five complete oscillations**, stopping the watch on the count of five. Divide the total elapsed time by five and record this value on the data sheet below as your first time trial. Repeat step 24.) four more times and determine the average value $\tau_{conf 2, measured}$ for the period of the rod.

25.) Calculate the percent difference between $\tau_{conf 2, theory}$ and $\tau_{conf 2, measured}$.

Data Sheet

Masses, Lengths and Centers of Mass

$$M_{rod} = \text{_____} \text{ kg}$$

$$M_{cy1} = \text{_____} \text{ kg}$$

$$D_{cy1} = \text{_____} \text{ m}$$

$$M_{cy2} = \text{_____} \text{ kg}$$

$$D_{cy2} = \text{_____} \text{ m}$$

$$d = \text{_____} \text{ m}$$

$$\ell = \text{_____} \text{ m}$$

$$d_3 = \text{_____} \text{ m}$$

$$d_4 = \text{_____} \text{ m}$$

$$C = \frac{d}{\ell} = \text{_____}$$

$$r_{rod} = \text{_____} \text{ m}$$

$$r_{conf1} = \text{_____} \text{ m}$$

$$r_{conf2} = \text{_____} \text{ m}$$

Calculation the Period of the Rod Itself

$$I_{rod} = \text{_____} \text{ kg m}^2$$

$$\tau_{rod, theory} = \text{_____} \text{ s}$$

Calculating the Period of Configuration One

$$I_{\text{cyl}} = \text{_____} \text{ kg m}^2$$

$$I_{\text{conf1}} = \text{_____} \text{ kg m}^2$$

$$M_{\text{conf1}} = \text{_____} \text{ kg}$$

$$\tau_{\text{conf1, theory}} = \text{_____} \text{ s}$$

Calculating the Period of Configuration Two

$$I_{\text{cy2}} = \text{_____} \text{ kg m}^2$$

$$I_{\text{conf2}} = \text{_____} \text{ kg m}^2$$

$$M_{\text{conf2}} = \text{_____} \text{ kg}$$

$$\tau_{\text{conf2, theory}} = \text{_____} \text{ s}$$

Measuring the Period of the Rod Itself

<i>Trial #</i>	<i>Time Values (s)</i>
1	
2	
3	
4	
5	

$$\tau_{\text{rod, measured}} = \text{_____} \text{ s}$$

% Difference between $\tau_{\text{rod, theory}}$ and $\tau_{\text{rod, measured}} = \text{_____}$

Measuring the Period of Configuration One

<i>Trial #</i>	<i>Time Values (s)</i>
1	
2	
3	
4	
5	

$$\tau_{conf1, measured} = \text{_____} s$$

% Difference between $\tau_{conf1, theory}$ and $\tau_{conf1, measured} = \text{_____}$

Measuring the Period of Configuration Two

<i>Trial #</i>	<i>Time Values (s)</i>
1	
2	
3	
4	
5	

$$\tau_{conf2, measured} = \text{_____} s$$

% Difference between $\tau_{conf2, theory}$ and $\tau_{conf2, measured} = \text{_____}$

PHY2053 LABORATORY

Experiment Eleven

The Ballistic Pendulum

THEORY

A small steel sphere of mass m leaves the barrel of a launcher with horizontal speed v_o . The ball collides with a "catcher" of mass M . The ball is "caught" by the catcher and the ball and catcher swing away together. In order to analyze this process, I am going to divide the process into two distinct phases. The first phase I will call the "collision phase," and the second phase I will call the "swing phase."

The Collision Phase (Conservation of Angular Momentum)

Figure One
The Collision Phase

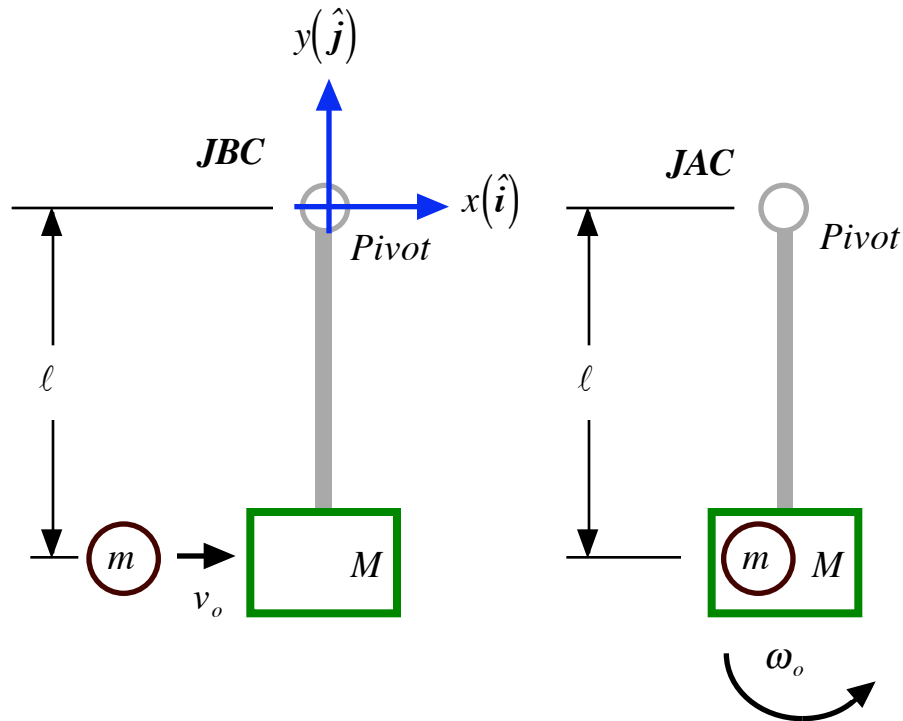

The collision between the ball and the catcher takes place over a very short time interval. During this interval there is no net torque on the system of ball and catcher. Therefore, the angular momentum is conserved. So, we have

$$\vec{I}_{ave,net} = \frac{\Delta \vec{L}_{syst}}{\Delta t} = 0 \quad , \quad (1)$$

which implies that

$$\Delta \vec{L}_{syst} = \vec{L}_{JAC} - \vec{L}_{JBC} = 0 \quad , \quad (2)$$

and that

$$\vec{L}_{JAC} = \vec{L}_{JBC} \quad . \quad (3)$$

At the instant just before the collision, the only physical thing moving is the ball. So, just before the collision, with respect to the pivot axis of the catcher, the ball has an angular momentum given by

$$\vec{L}_{JBC} = \vec{r}_{JBC} \times \vec{p}_{JBC} = [-\ell \hat{j}] \times [mv_o \hat{i}] = \ell mv_o \hat{k} . \quad (4)$$

At the instant just after the collision, which also constitutes the beginning of the swing phase, both the ball and the catcher are swinging with respect to the pivot with the same angular speed ω_o . Therefore,

$$\vec{L}_{JAC} = I_{sys} \omega_o \hat{k} , \quad (5)$$

where I_{sys} is the moment of inertia of the system--ball and catcher--with respect to the pivot axis.

Later, we will have to determine what I_{sys} is. Comparing equations (4) and (5), we have

$$I_{sys} \omega_o = \ell mv_o , \quad (6)$$

and

$$\omega_o = \frac{\ell mv_o}{I_{sys}} . \quad (7)$$

The Swing Phase (Conservation of Mechanical Energy)

During the **swing phase**, the total mechanical energy is conserved as the only force doing work on the system of ball and catcher is the force of gravity. (We ignore the frictional losses at the pivot and losses due to air resistance. Obviously, we can ignore these forces for a short time only!) We write

$$K_{JAC} + U_{JAC}^G = K_{ESP} + U_{ESP}^G . \quad (8)$$

Figure Two
The Swing Phase

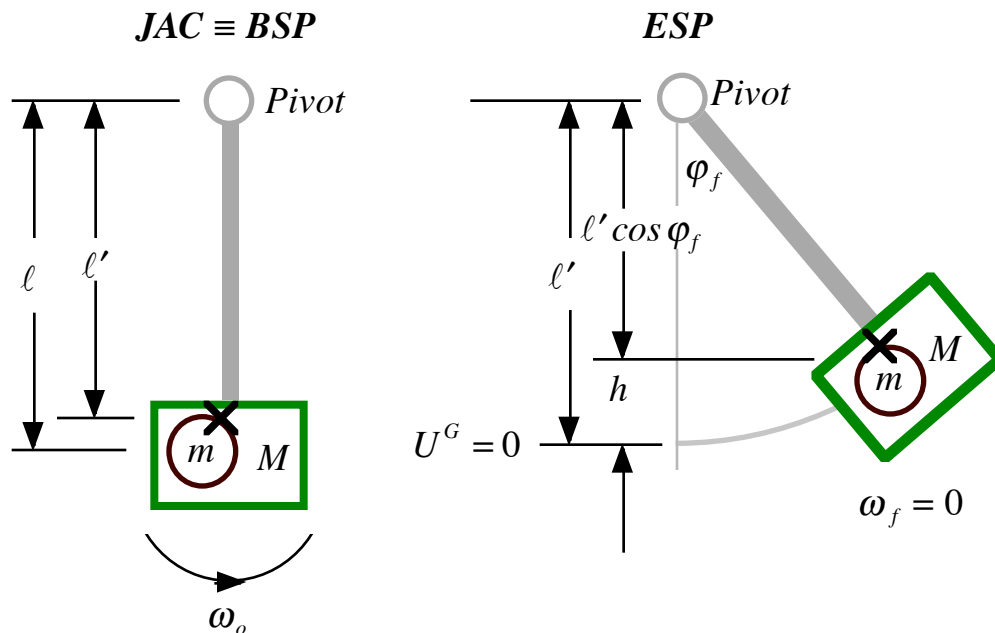

Assigning the gravitational potential energy to be zero at the level of the center of mass at the beginning of the swing phase, and noting that the distance from the pivot to the center of mass is ℓ' , then equation (8) becomes

$$\frac{1}{2}I_{sys}\omega_o^2 + 0 = 0 + (m + M)g[\ell' - \ell' \cos\varphi_f] , \quad (9)$$

where φ_f is the angle the pendulum makes with the vertical at the instant it stops swinging, and the vertical distance of the center of mass relative to the zero point is given by

$$h = [\ell' - \ell' \cos\varphi_f] = \ell'(1 - \cos\varphi_f) . \quad (10)$$

Substitution of equations (7) and (10) into equation (9) yields

$$\frac{1}{2}I_{sys} \left[\frac{\ell m v_o}{I_{sys}} \right]^2 = (m + M)g\ell'(1 - \cos\varphi_f) , \quad (11)$$

and

$$v_o = \sqrt{\frac{2I_{sys}(m + M)g\ell'(1 - \cos\varphi_f)}{m^2\ell^2}} . \quad (12)$$

The Moment of Inertia of the Ball and Catcher

Everything in equation (12) is easily measured except the moment of inertia of the system, I_{sys} . Recall that m is the mass of the ball and M is the mass of the catcher. The acceleration due to gravity, g , is well known, and φ_f is the angle the pendulum makes with the vertical at the instant it stops its swing. The distance from the pivot to the center of mass of the ball is ℓ , while the distance from the pivot to the center of mass of the system is ℓ' . We need to find I_{sys} !

If we were to put the ball into the catcher and remove the launcher, we would have a pendulum, see Figure Three below. If we were to pull the pendulum aside some **small angle** φ_o and release it from rest, it would oscillate as any pendulum does. Further, if we were to look at the tangential force that acts on the pendulum, we would have

$$\vec{F}_{tan} = -(m + M)g \sin\varphi \hat{\varphi} . \quad (13)$$

This force produces, with respect to the pivot, a torque given by

$$\begin{aligned} \vec{\Gamma} &= \vec{r} \times \vec{F} = [\ell' \hat{r}] \times [-(m + M)g \sin\varphi \hat{\varphi}] \\ &= -\ell'(m + M)g \sin\varphi \hat{r} \times \hat{\varphi} \\ &= -\ell'(m + M)g \sin\varphi \hat{k} . \end{aligned} \quad (14)$$

Now, we recall that the torque can also be defined by

$$\vec{\Gamma} = I_{sys} \alpha \hat{\Gamma} = -\ell'(m + M)g \sin\varphi \hat{k} , \quad (15)$$

and, therefore,

$$\alpha = \frac{d^2\varphi}{dt^2} = \left[\frac{-\ell'(m + M)g}{I_{sys}} \right] \sin\varphi . \quad (16)$$

An exact solution of equation (16) is very complicated and requires an infinite series of terms.

However, if we limit ourselves to small initial angular displacements, then we can solve equation (16) using **the small angle approximation**. For small angles, in radian measure, $\sin \varphi \approx \varphi$, and equation (16) becomes

$$\alpha = \frac{d^2\varphi}{dt^2} \approx \left[\frac{-\ell'(m+M)g}{I_{\text{sys}}} \right] \varphi . \quad (17)$$

One solution to equation (17) has the form

$$\varphi = \varphi_o \cos(\omega't) , \quad (18)$$

where ω' is a constant called the angular frequency and not to be confused with the instantaneous angular speed ω . The angular speed ω is given by

$$\omega = \frac{d\varphi}{dt} = \frac{d}{dt} [\varphi_o \cos(\omega't)] = -\omega' \varphi_o \sin(\omega't) , \quad (19)$$

while the angular acceleration α is given by

$$\alpha = \frac{d\omega}{dt} = \frac{d}{dt} [-\omega' \varphi_o \sin(\omega't)] = -\omega'^2 \varphi_o \cos(\omega't) . \quad (20)$$

Substitution of equations (20) and (18) into equation (17) gives us

$$-\omega'^2 \varphi_o \cos(\omega't) = \left[\frac{-\ell'(m+M)g}{I_{\text{sys}}} \right] \varphi_o \cos(\omega't) . \quad (21)$$

Figure Three
The System as a Physical Pendulum

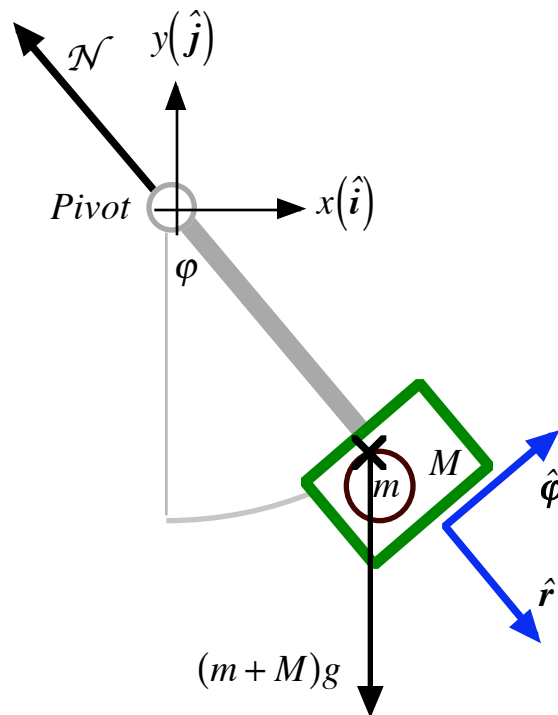

Equation (21) can be true if and only if

$$\omega'^2 = \left[\frac{\ell'(m+M)g}{I_{sys}} \right]. \quad (22)$$

$$\omega' = \sqrt{\frac{\ell'(m+M)g}{I_{sys}}} = 2\pi f = \frac{2\pi}{\tau}. \quad (23)$$

We square both sides of equation (23) and get

$$\frac{\ell'(m+M)g}{I_{sys}} = \frac{4\pi^2}{\tau^2}, \quad (24)$$

and, finally,

$$I_{sys} = \frac{\ell'(m+M)g\tau^2}{4\pi^2}. \quad (25)$$

Substitution of equation (25) into equation (12) yields

$$\begin{aligned} v_o &= \sqrt{\frac{2 \left[\frac{\ell'(m+M)g\tau^2}{4\pi^2} \right] (m+M)g\ell'(1-\cos\phi_f)}{m^2\ell^2}} \\ &= \sqrt{\frac{(m+M)^2 g^2 \ell'^2 \tau^2 (1-\cos\phi_f)}{2\pi^2 m^2 \ell^2}} = \sqrt{\frac{(m+M)^2}{m^2} \frac{g^2 \ell'^2 \tau^2}{\pi^2 \ell^2} \frac{(1-\cos\phi_f)}{2}} \\ v_o &= \left(\frac{m+M}{m} \right) \left(\frac{\ell'}{\ell} \right) \left(\frac{g\tau}{\pi} \right) \sqrt{\frac{1-\cos\phi_f}{2}}. \end{aligned} \quad (26)$$

Conservation of Linear Momentum Also?

Our analysis was predicated on the **conservation of angular momentum** during the collision phase. It may have occurred to you that there should be conservation of linear momentum as well. If there were conservation of linear momentum, we would have

$$mv'_o = (m+M)v_{JAC}. \quad (27)$$

Again, using the conservation of mechanical energy during the swing phase, we have

$$\frac{1}{2}(m+M)v_{JAC}^2 = (m+M)gh_L = (m+M)g\ell'(1-\cos\phi_f). \quad (28)$$

So, we have

$$v_{JAC} = \sqrt{2g\ell'(1-\cos\phi_f)}. \quad (29)$$

Substitution of equation (25) into equation (23) gives us

$$mv'_o = (m+M)\sqrt{2g\ell'(1-\cos\phi_f)}, \quad (30)$$

and

$$v'_o = \left(\frac{m + M}{m} \right) \sqrt{2g\ell'(1 - \cos\phi_f)} . \quad (31)$$

Comparing equations (31) and (26) we see that **they are not the same**, and, therefore, **both quantities cannot be conserved**. The angular momentum is conserved.

PHY2053 LABORATORY

Experiment Eleven

The Ballistic Pendulum

Name:

Date:

Day and Time:

EQUIPMENT NEEDED

Ballistic Pendulum Apparatus
One Two-meter Stick
One Steel Ball
Carbon Paper

One Stopwatch
One One-meter Stick
Paper
Masking Tape

PROCEDURE

- 1.) Set up and level the launcher. Make sure the **indicator** used to measure the final swing angle is set to zero. Fire the steel ball into the catcher and record the value of the final swing angle, ϕ_f , on the data sheet. Do this for a total of **five** times and get an average final angle measure.
- 2.) Remove the launcher. Using the stopwatch as your timer, pull the pendulum--**with the steel ball inside**--to the side an angle of $\approx 15^\circ$ and release the pendulum from rest. Time the pendulum for **five complete swings**. Divide this total time by five to get an average period. Record the measured value of the period of the swing. Do this **five** times and calculate an average value for the period of the system and record the value.
- 3.) Take the pendulum off of the apparatus. Measure the mass of the catcher, M , and record the value. Measure the mass of the steel ball, m , and record the value.
- 4.) Measure the distance from the pivot to the center of the ball, ℓ , and record the value. Next, measure the distance from the pivot to the center of mass of the system, ℓ' , and record the value. (To determine the center of mass of the system, try to balance the system on the edge of a meter stick.)
- 5.) Using the values that you have measured, calculate the initial speed, v_o . (Remember, this assumes the **conservation of angular momentum**.)
- 6.) Using the values that you have measured, calculate the initial speed, v'_o . (Remember, this assumes the **conservation of linear momentum**.)
- 7.) Calculate the percent difference between the two initial speed calculations and record this on the data sheet.

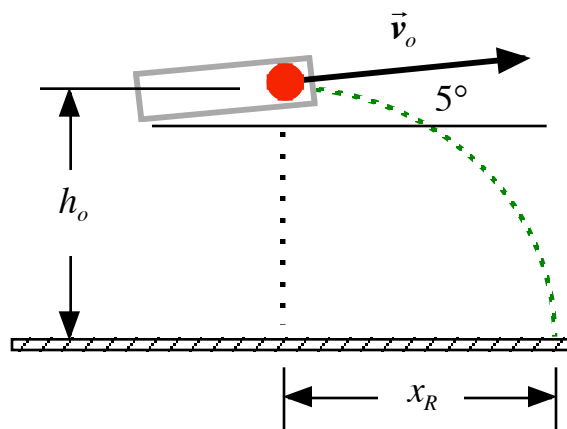

- 8.) Leaving the pendulum off of the apparatus, reattach the launcher adjust it to shoot at five *degrees*. Load the launcher and fire it off of the table top in a direction that is clear. (**Remember, do not shoot anyone or break anything! Safety is our most important concern!**) Measure carefully the horizontal distance, x_R , and the initial vertical distance the ball is above the floor, h_o , and record these values. From the same vertical height, repeat this process four more times and record the values. Calculate an average range value.

- 9.) Calculate the initial speed of the ball, $v_{o, meas}$.
- 10.) Calculate and record the percent difference between v_o and $v_{o, meas}$.
- 11.) Calculate and record the percent difference between v_o' and $v_{o, meas}$.
- 12.) Decide which conservation law the data appears to support best.
- 13.)
 - a) If you believe the linear momentum is conserved, please identify which external torque vitiates the conservation of angular momentum during the collision.
 - b) If you believe the angular momentum is conserved, please identify which external force vitiates the conservation of linear momentum during the collision.

Data Sheet

Measuring the Maximum Angular Swing of the Pendulum and Projectile:

	Trial 1	Trial 2	Trial 3	Trial 4	Trial 5
φ_f					

Average: $\varphi_f = \underline{\hspace{2cm}}^\circ$

$\ell = \underline{\hspace{2cm}} m$

$\ell' = \underline{\hspace{2cm}} m$

Measuring the Period of the Pendulum and Projectile:

	Trial 1	Trial 2	Trial 3	Trial 4	Trial 5
τ					

Average: $\tau = \underline{\hspace{2cm}} s$

$m = \underline{\hspace{2cm}} kg$

$M = \underline{\hspace{2cm}} kg$

Value of the Initial Speed for the Conservation of Angular Momentum:

$$v_o = \frac{(m + M)}{m} \frac{\ell'}{\ell} \frac{g\tau}{\pi} \sqrt{\frac{1 - \cos \varphi_f}{2}} = \underline{\hspace{2cm}} \frac{m}{s}$$

Value of the Initial Speed for the Conservation of Linear Momentum:

$$v'_o = \left(\frac{m + M}{m} \right) \sqrt{2g\ell'(1 - \cos \varphi_f)} = \underline{\hspace{2cm}} \frac{m}{s}$$

% Difference between v_o and v_o' : _____

Measured Value of the Initial Speed Using A Horizontal Launching Procedure:

$$h_o = \text{_____} m$$

	<i>Trial 1</i>	<i>Trial 2</i>	<i>Trial 3</i>	<i>Trial 4</i>	<i>Trial 5</i>
x_R					

Average: $x_R = \text{_____} m$

$$v_{o,meas} = x_R \sqrt{\frac{g}{x_R \sin 2\theta_o + 2h_o (\cos \theta_o)^2}} = \text{_____} \frac{m}{s}$$

% Difference between v_o and $v_{o,meas}$: _____

% Difference between v_o' and $v_{o,meas}$: _____

As suggested in the introduction, the angular momentum is conserved and not the linear momentum. In the space below, I want you to identify which specific **external force acting on the system during the collision** prevents the linear momentum from being conserved. (Hint: Imagine the catcher lying on a level piece of ice **without an axle** and a moving ball colliding and being “caught”, with the collision being just below the center of mass of the system. Imagine how and why that motion is different from what goes on during the collision you observed.)

PHY2053 LABORATORY

Experiment Twelve

Standing Waves on a String

THEORY

In Figure One below, we have a pictorial representation of the equipment we will use in today's experiment. A vibrator that oscillates with an effective frequency $f = 120 \text{ Hz}$ is attached to a vertical post. One end of a string is tied to the vibrator. The string passes over a pulley and at the other end of the string is attached a **total mass** M . The distance between the end of the vibrator and the point at which the string makes contact with the pulley is measured to be L .

Figure One

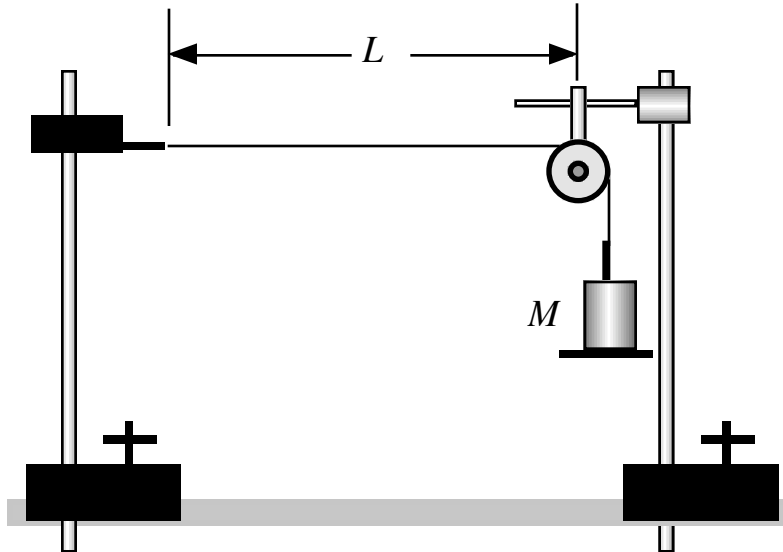

The vibrator sends waves down the string. In turn, waves are reflected back from the pulley. These traveling waves interfere with each other. Under certain specifiable conditions, the waves constructively interfere and produce standing waves. Before we can understand this process, we need to know a little bit about waves.

In the natural world, there are many processes which repeat themselves on a regular basis. It is often the case that in the mathematical description of these processes, the sine function or the cosine function is used. In Figure Two below, we have a graph of a sine wave function given by

$$y = A \sin(x) . \quad (1)$$

If you look carefully at the graph of the sine wave, you can see that the function values oscillate between two extreme values; that is

$$-A \leq y \leq A . \quad (2)$$

The magnitude of these extreme values is A , and A is called the **amplitude** of the wave.

The first value of the sine function graphed below is at $x = 0$, for which $y = A \sin(0) = 0$. The function values then increase until they reach a maximum value at $x = \pi / 2$, for which $y = A \sin(\pi / 2) = A$. Also, notice that at $x = \pi$, $y = A \sin(\pi) = 0$. While the function value is indeed again at zero, the "trend" of the values of the function is toward a negative A . The next time the function is at zero and trending toward a positive A is when $x = 2\pi$. So, this function repeats itself over an x -interval of 2π .

If you look carefully at points B and C , you will note that they are adjacent points that have the same function value and they are also in the same "trend." The same thing can, of course, be

said about points D and E . However, while points E and F have the same functional value, they are not “trending” the same. Points that have the same functional value and are trending the same are said to be **in phase**. The actual straight-line distance between any two adjacent points that are in phase is called the **wavelength**, and given the symbol λ .

Figure Two
The Graph of a Sine Wave
 $y = A \sin(x)$

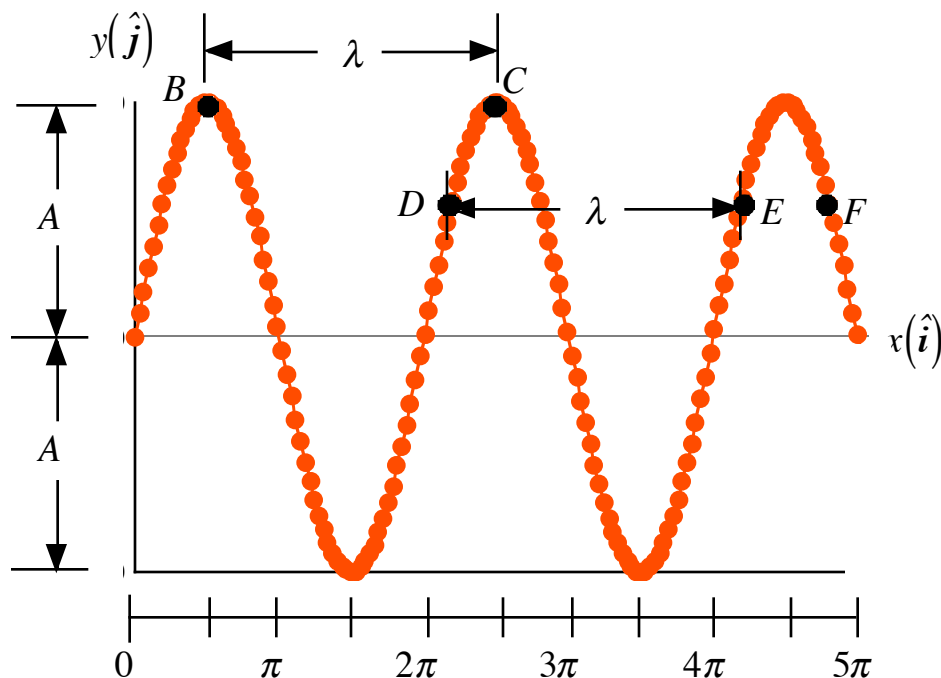

Imagine grabbing one end of a taut horizontal rope. (The other end of the rope is fixed.) If you vigorously move the free end of the rope up and down, you can send a wave pulse down the rope. This state of affairs is represented graphically below in Figure Three. The actual particles of the rope are moving up and down parallel to the y -axis while the energy of the wave is moving perpendicular to the particle motion and parallel to the x -axis. A wave that propagates perpendicular to the particle motion is called a **transverse wave**. (Waves--such as sound waves--where the energy moves parallel to the actual particle motion are called **longitudinal waves**.) Inspection of the diagram below should convince you that if the wave is moving with constant speed v , then in a time interval of Δt the peak of the wave will move a distance Δx to the right.

The distance the wave travels in a given period of time depends on the speed with which it moves along the string. It turns out that the speed at which energy is being propagated by any wave phenomenon is given by

$$v = f\lambda, \quad (3)$$

where f is the frequency measured in *Hertz* (cycles per *second*), and λ is the wavelength measured in *meters*. (Physically, the frequency is telling us about the oscillations of the atoms of the medium through which the wave propagates. The atoms oscillate about their equilibrium positions.)

Figure Three
A Wave Pulse Moving along a String

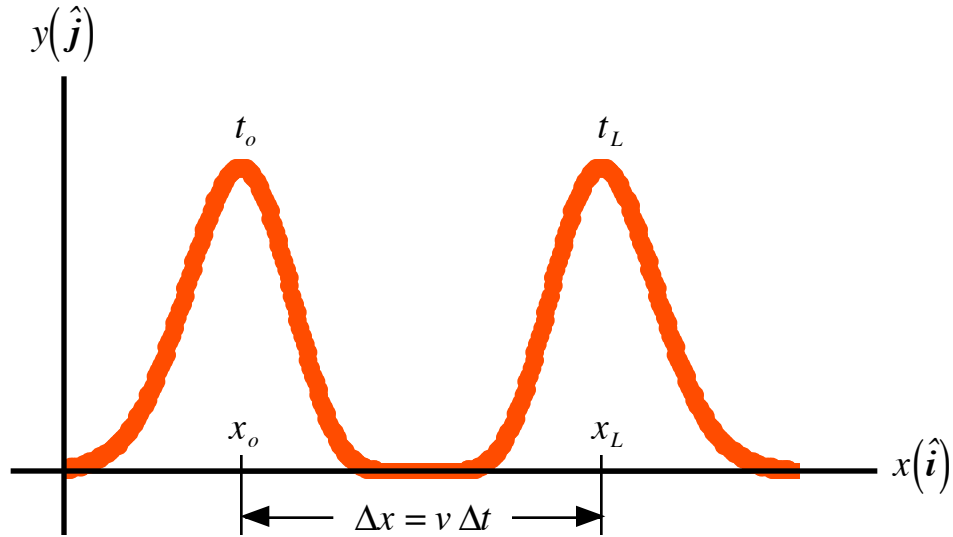

Let us take another approach and see if we can figure out what this speed should depend on in terms of our string under tension. Consider the free-body diagram of a small mass segment of our pulse as represented below in Figure Four. The radial force--we assume the path of motion to be circular--is given by

$$2T \sin(\Delta\theta) = \frac{(\Delta M)v^2}{R} = \frac{\mu(\Delta\ell)v^2}{R} = \frac{\mu(R(\Delta\theta))v^2}{R} = 2\mu(\Delta\theta)v^2, \quad (4)$$

where μ is the linear mass density of the string, and ΔM represents a small piece of the mass of the string, and $\Delta\theta$ is measured in *radians*. As the angle is small and measured in *radians*, we can use

$$\sin(\Delta\theta) \approx \Delta\theta, \quad (5)$$

so that equation (4) becomes

$$2T(\Delta\theta) = 2\mu(\Delta\theta)v^2, \quad (6)$$

and the speed is given by

$$v = \sqrt{\frac{T}{\mu}} = \sqrt{\frac{Mg}{\mu}}, \quad (7)$$

where we note that the tension in the string is equal to the suspended weight, that is,

$$T = Mg. \quad (8)$$

Using equations (7) and (3), we have

$$f\lambda = \sqrt{\frac{Mg}{\mu}}. \quad (9)$$

Figure Four
A Free-Body Diagram

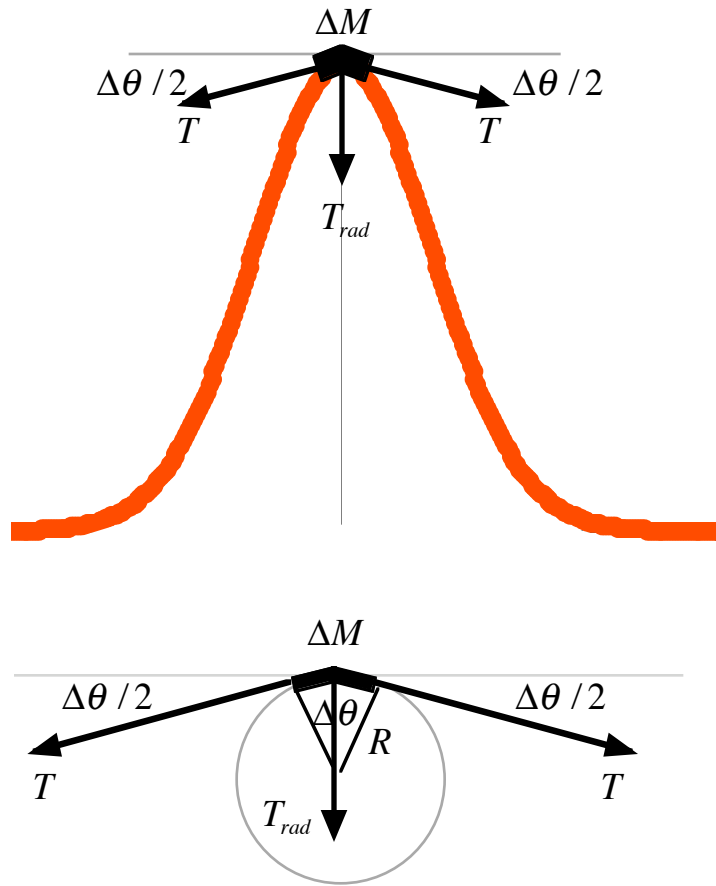

Next, under special conditions, the waves traveling toward the pulley can constructively interfere with the reflected waves. When this happens, we have a resonance phenomenon and the string takes on a standing wave pattern. There are, in principle, an infinite number of such patterns that can be produced. In reality, the actual number one can observe is quite small. The conditions for producing standing waves is that the distance between the end of the vibrator and the point of contact of the pulley be some integer multiple of half-wavelengths. (Some examples of this are represented below in Figure Five.) That is,

$$L = n \left(\frac{\lambda_n}{2} \right) . \quad (10)$$

Using equations (9) and (10), and solving for the wavelength, we find

$$\lambda_n = \frac{2L}{n} = \frac{1}{f} \sqrt{\frac{M_n g}{\mu}} = \frac{1}{f} \sqrt{\frac{g}{\mu}} \sqrt{M_n} . \quad (11)$$

Equation (10) must be satisfied for each and every value of n . (Recall that n must be a positive integer, that is, $n = 1, 2, 3, 4, \dots$.) Let us look at equation (11) and see if we can use it to make some predictions about our system of standing waves. First, we rearrange and write the equation as

$$\frac{2L}{n} = \sqrt{\frac{g}{\mu f^2}} \sqrt{M_n} . \quad (12)$$

Next, we square both sides of equation (12) and solve for the suspended mass. We find

$$M_n = \frac{4L^2 \mu f^2}{gn^2} = \frac{1}{n^2} \left[\frac{4\mu(Lf)^2}{g} \right]. \quad (13)$$

Close inspection of equation (13) should convince you that the bracketed term is the predicted amount of mass that will be necessary to get the so-called fundamental standing wave; that is, the mass when $n = 1$. So, for $n = 1$, we have

$$M_1 = \left[\frac{4\mu(Lf)^2}{g} \right], \quad (14)$$

while for all other n , we have

$$M_n = \left(\frac{1}{n^2} \right) M_1. \quad (15)$$

Now, let's do the experiment and see how well the theory predicts these masses.

Figure Five
Constructive Interference Standing Wave Patterns

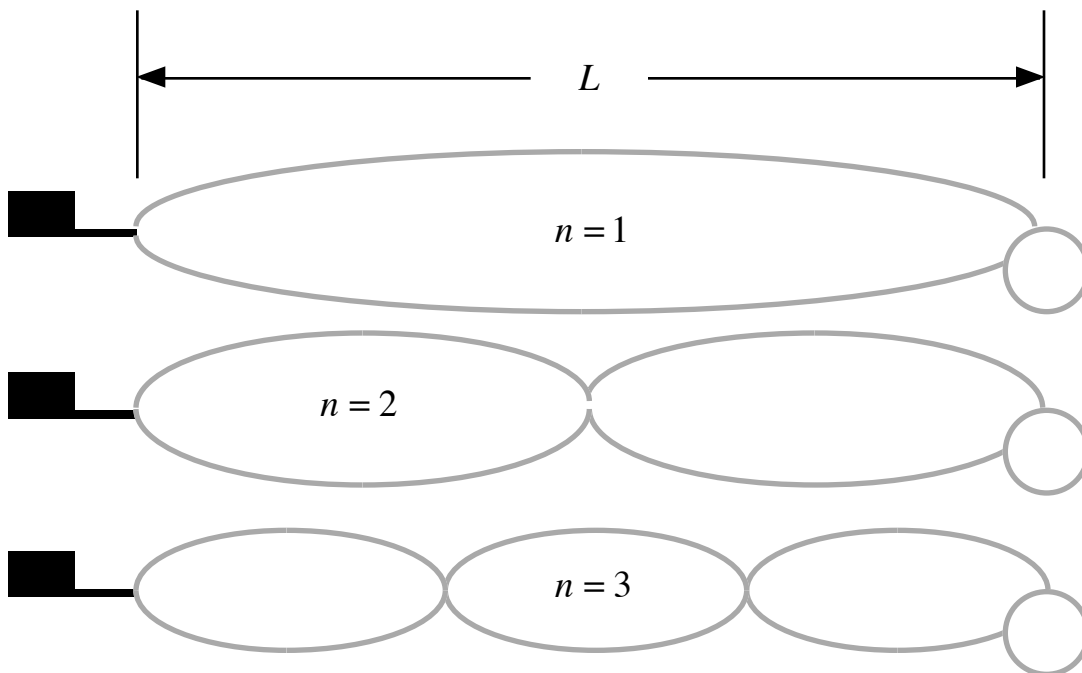

PHY2053 LABORATORY

Experiment Twelve

Standing Waves on a String

Name:

Date:

Day and Time:

EQUIPMENT NEEDED

Two Vice Clamps
One New 120 Hz Vibrator
One Small Pulley Clamp
Kevlar Thread
Mass Scales
One Set of Slotted Masses
One Two-meter Stick

Two Support Poles
One Pulley
One Small Pulley Rod
Scissors
One 50 gram Mass Hanger
Access to Smaller masses

PROCEDURE

This procedure assumes that you have Kevlar thread to use. Note that the average mass density for this thread is

$$\mu = 5.73 \times 10^{-5} \text{ kg / m .}$$

Figure One

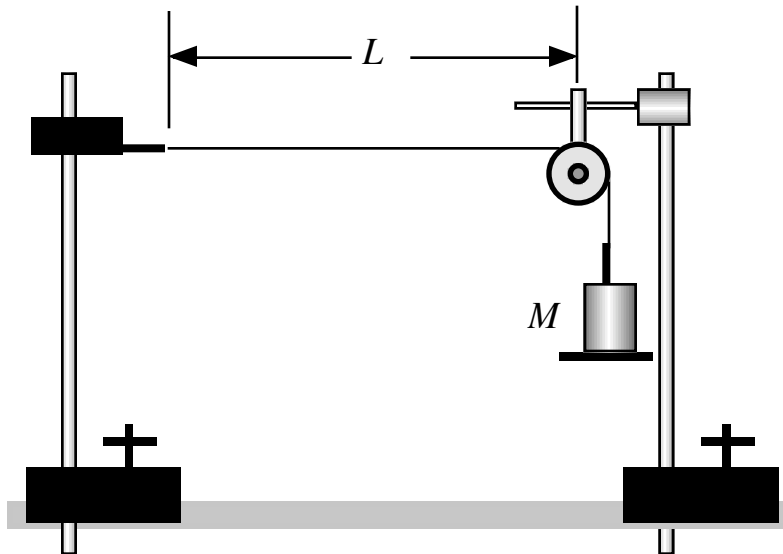

1.) Cut off a piece of the Kevlar thread $\ell \approx 2.15 \text{ m}$ in length. As the Kevlar thread is so light, we are going to want the distance between the vibrator and the pulley to be

$$L = 2.000 \text{ m .}$$

2.) With the vibrator unplugged, set up the equipment as represented in Figure One above. One end of the Kevlar thread is to be attached to the eyelet of the vibrator. The string is to pass over the pulley and the mass hanger is to be attached to the other end of the string. Set it up so that the distance between the end of the vibrator and the point where the string makes contact with the pulley is value of L given above.

(It is very important to make sure that the vice clamps are fastened securely to the table top and that the support poles are fastened securely to the clamps, and that the vibrator and pulley assembly are fastened securely to the poles. **Safety is very important! Always be aware of where your feet are. Try to make sure that toes and other breakable things are never directly under the hanging masses.**)

3.) Using equation (14), calculate the theoretical value of the mass needed to get a single loop

standing wave. Record this value on the data sheet.

4.) Calculate, using equations (16) and (17) below, the theoretical value of the mass need to get a two loop standing wave. Record this value on the data sheet.

5.) Repeat step seven for standing wave patterns of three and four loops. Record these values on the data sheet.

6.) Plug in the vibrator and place masses on the mass hanger until you determine **the actual amount of mass** needed to get a single loop standing wave. Record this value on the data sheet.

7.) Repeat step nine determining the actual masses needed for two, three and four loop standing wave patterns. Record these values on the data sheet, and unplug the vibrator.

8.) On the graph paper provided, plot a graph of λ_n versus $\sqrt{M_n^{meas}}$, see equation (18).

9.) Determine the slope of your graph.

10.) Use the slope of your graph to determine an experimental measure of the frequency f of the vibrator.

11.) Calculate the per cent difference between you calculated value of the frequency and the value given by the manufacturer.

Data Sheet

Mass density of the Kevlar thread:

$$\mu = 5.73 \times 10^{-5} \text{ kg / m .}$$

Distance between vibrator and pulley:

$$L = 2.000 \text{ m .}$$

Frequency of the vibrator:

$$f = 120 \text{ Hz .}$$

Acceleration due to gravity:

$$g = 9.789 \frac{\text{m}}{\text{s}^2} .$$

Recall that

$$M_1^{calc} = \left[\frac{4\mu(Lf)^2}{g} \right] , \quad (14)$$

while

$$M_n = \left(\frac{1}{n^2} \right) M_1 . \quad (15)$$

Calculated and Measured Mass Values

n	$\lambda_n = (2L) / n$ (m)	M_n^{calc} (kg)	M_n^{meas} (kg)	$\sqrt{M_n^{meas}}$ (kg) ^{1/2}
1				
2				
3				
4				

The Resonance Wavelength as a Function of the Square Root of the Driving Mass

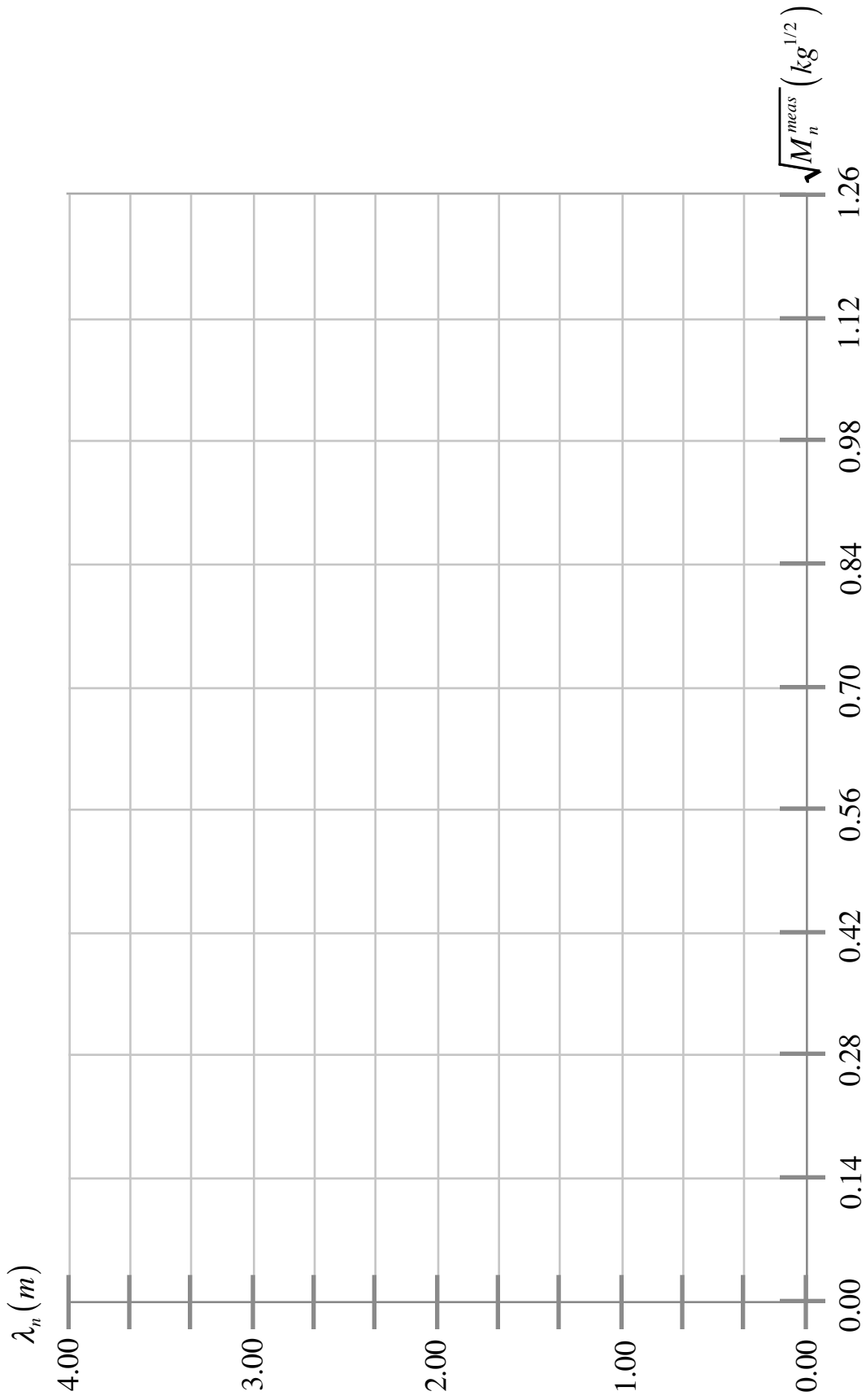

The slope of your graph:

$$\text{slope} = \frac{m}{kg^{1/2}} .$$

Recall that

$$\lambda_n = \left(\sqrt{\frac{g}{\mu f^2}} \right) \sqrt{M_n} = \left(\frac{1}{f} \sqrt{\frac{g}{\mu}} \right) \sqrt{M_n} . \quad (16)$$

Equation (16) is linear and, therefore, implies that the slope is equivalent to

$$\text{slope} \equiv \frac{1}{f} \sqrt{\frac{g}{\mu}} , \quad (17)$$

while,

$$f_{meas} = \frac{\sqrt{g / \mu}}{\text{slope}} . \quad (18)$$

Using equation (18) calculate your measured frequency

$$f_{meas} = \text{_____} \text{ Hz} .$$

The percent difference between the given frequency f and the measured frequency f_{meas} is:

$$\% \text{ Diff} = \text{_____} .$$

PHY2053 LABORATORY

Make-Up Lab

The Thermal Coefficient of Linear Expansion

THEORY

If we subject a strip of metal to a source of thermal energy, the metal will expand. The factors which contribute to the amount of expansion, $\Delta\ell$, are threefold. First, the amount of expansion depends on the original length of the strip, ℓ_o . Second, the amount of expansion depends on the change in temperature of the metallic strip, ΔT . Third, the amount of expansion depends on the particular kind of metal we are using. The contribution of the specific metal is a quantity called the **coefficient of linear expansion**, and signified by the Greek letter α . (Please do not confuse this with the angular acceleration.) Over a wide range of temperatures, it is found that the amount of expansion is related to these three factors by

$$\Delta\ell = \alpha \ell_o \Delta T, \quad (1)$$

where lengths are measured in *meters*, and temperatures are measured in *degrees Celsius*, $^{\circ}\text{C}$. Using equation (1), we can write

$$\alpha = \frac{\Delta\ell}{\ell_o \Delta T}. \quad (2)$$

So, to experimentally determine the coefficient of linear expansion of a particular metal, we are going to need a sample of that metal. In this lab, we are going to use an aluminum rod. We are going to have to measure the initial length of the rod and the initial temperature of the rod. Next, we are going to introduce some thermal energy to the rod in the form of steam. This will cause the rod to expand so our most crucial measurement is, of course, the amount by which the rod expands. For this measurement, we are going to use a free-sliding probe that can measure to a precision of 0.01 mm . Once the rod and the steam come to thermal equilibrium, then we will know that the rod is at a final temperature of $T_f = 100^{\circ}\text{C}$.

EQUIPMENT NEEDED

One Aluminum Rod	One Linear Expansion Apparatus
One Bunsen Burner	One Half Filled Water Reservoir
One Flint Striker	One Reservoir Stand
One Asbestos Wire-Mesh Pad	One One-meter Stick
Two Pointer Clamps	One Temperature Probe
One Small Beaker	A Small Stack of Paper Towels

PROCEDURE

- 1.) Using the meter stick and the two pointer clamps, measure the initial length ℓ_o of the aluminum rod and record this value on the data sheet. (Be sure to handle the aluminum rod with the paper towels so as to minimize temperature changes in the rod.)

Figure One

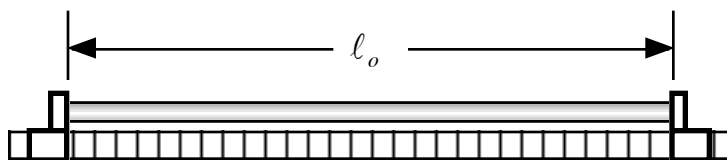

- 2.) As the aluminum rod has been sitting out in the room for some time, we will make the assumption that the rod and the room are in thermal equilibrium, and, therefore, at the same temperature. Use the temperature probe to measure the initial temperature of the rod, T_o , and record this value on the Data Sheet. (Be sure to use the Celsius scale.)
- 3.) Using paper towels to handle the rod, slide the rod into the steam jacket of the linear expansion apparatus. (Very little of the rod will be sticking out of the cylindrical steam jacket.)

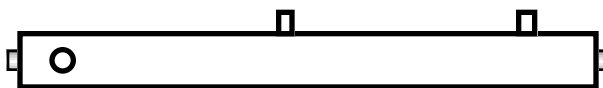

- 4.) Carefully place the steam jacket and rod on the apparatus base. The rod should be in contact with the free-sliding probe on the right, and the tip of the metal screw on the left. **Adjust things so that your initial scale reading is close to zero! (You need room for expansion!)**

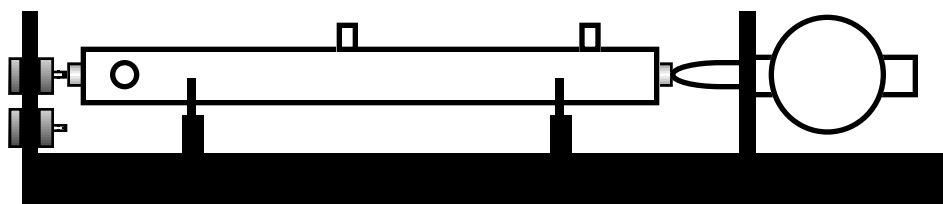

- 5.) The steam jacket should have a small hose attached at the left end of the steam jacket as shown above. (In the view above, the hose is represented by the circle at the left end of the steam jacket.) Make sure that the hose empties into a small beaker. (Later, there will be condensation from the steam; we do not want it on the table.)

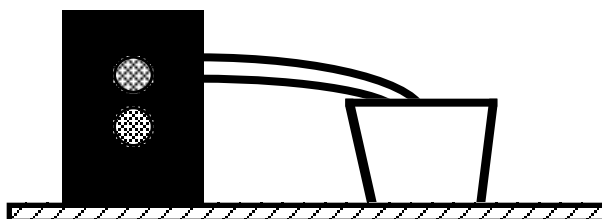

- 6.) **With the gas shutoff,** connect the hose of the Bunsen burner to the gas outlet.

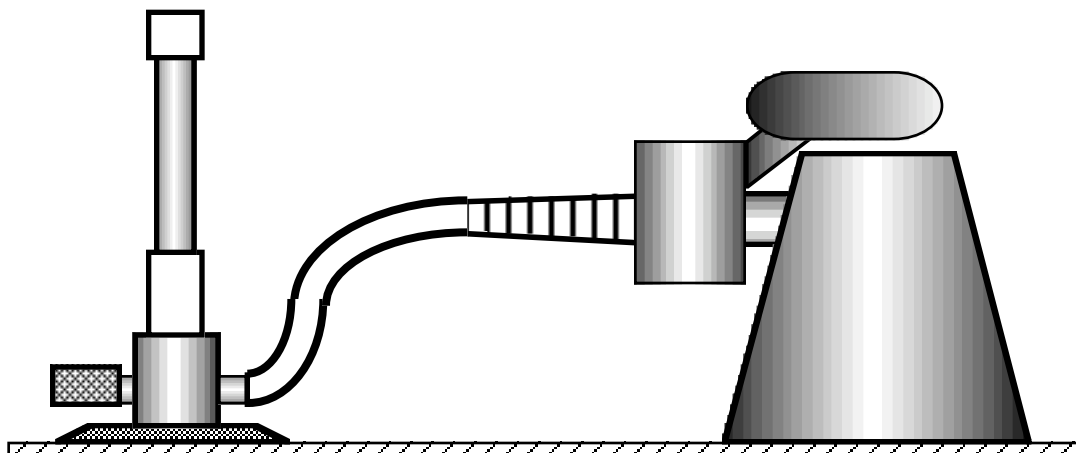

- 7.) Place the asbestos wire-mesh pad on top of the reservoir stand and then place the water reservoir on top of the stand. Attach the hose of the water reservoir to the steam jacket. Use the rightmost nipple on the steam jacket as shown in the diagram below.

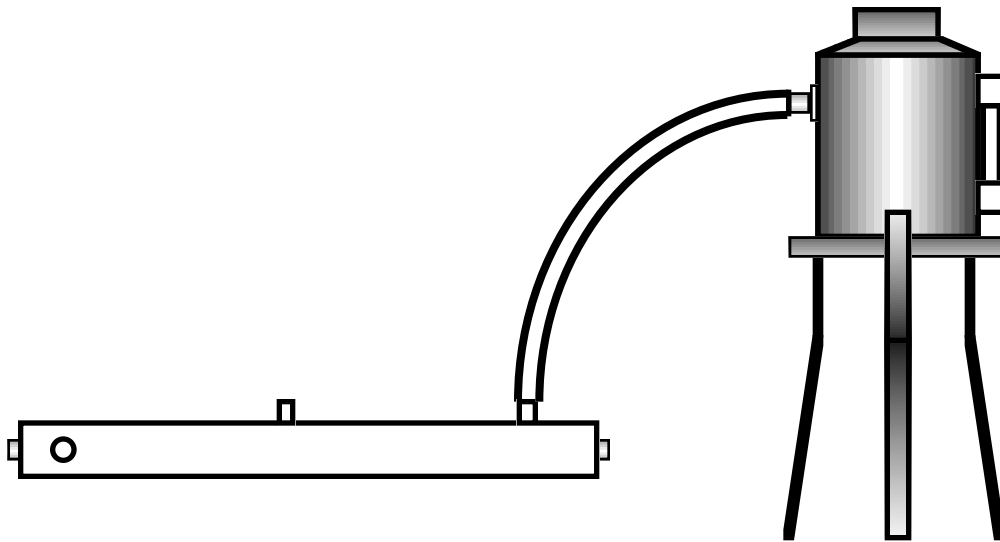

- 8.) One final measurement must be made before we can turn on the gas and light the fire. Now you need to record the initial value on the free-sliding probe dial.

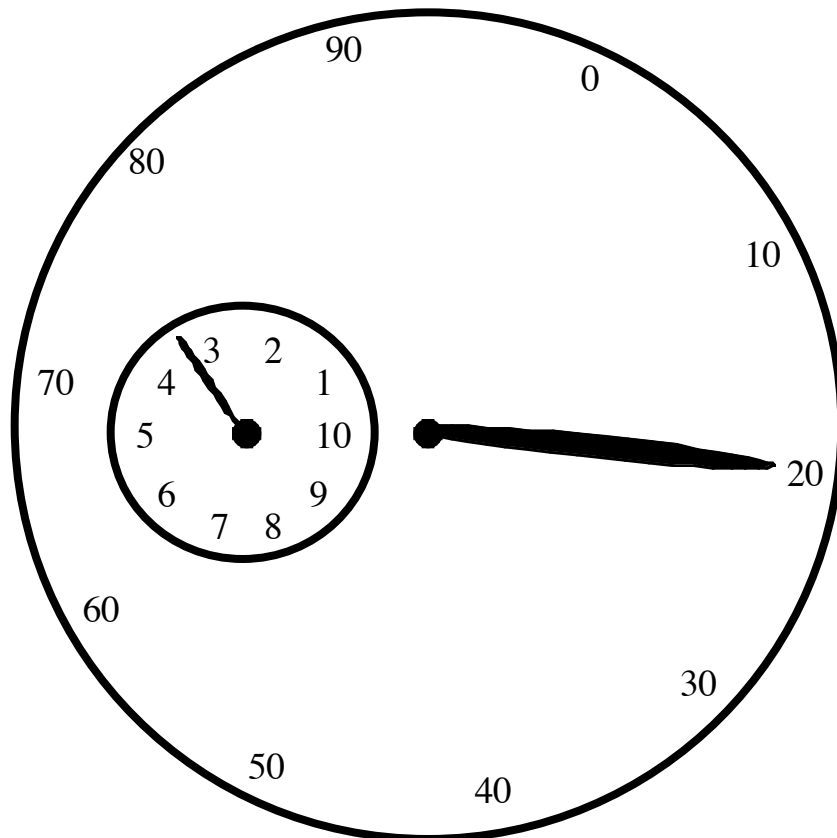

In the diagram shown above--a model of the dial on you linear expansion apparatus--the values on the rim of the large circle represent **hundredths** of a *millimeter*. So, the smallest change that can be measured directly on this machine is 0.01 mm . The numbers on the small circle represent whole *millimeters*. So, the value shown on the dial above is 3.20 mm . Using this information, read the value on the dial of your apparatus and record the initial dial reading, D_o , on the data sheet.

Please Think Safety! Do Not Burn Yourself, Or Anyone Else!

- 9.) Now we are ready to “cook with gas!” After I have turned on the main gas switch, you turn on you local valve and use the flint striker to ignite a flame with the Bunsen burner. Adjust the oxygen until you have a good flame. Slide the burner under the water reservoir so that we can begin to “dump” thermal energy into the water. **Now, wait for the water to boil!**
- 10.) When steam begins to escape from the steam jacket, put a thermal probe into the center nipple of the steam jacket to monitor the temperature of the rod.

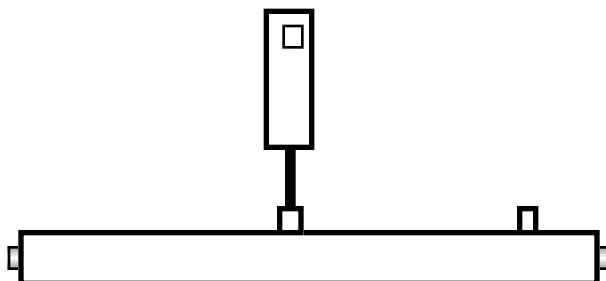

(Note that as the temperature increases the value on the dial should also begin to increase.)

- 11.) Once the temperature on the probe has been 100°C for about one minute, then take the final reading on the dial, D_f , and record this value on the data sheet. Also, record the final temperature value of the rod. **NEXT, TURN OFF ALL OF THE GAS AT YOUR STATION!**
- 12.) Perform the requested calculations, and turn in your lab report.

PHY2053 LABORATORY

Make-Up Lab

***The Thermal Coefficient
of Linear Expansion***

Name:

Date:

Day and Time:

Data Sheet

$$\ell_o = \underline{\hspace{2cm}} m$$

$$T_o = \underline{\hspace{2cm}} ^\circ C$$

$$T_f = \underline{\hspace{2cm}} ^\circ C$$

$$\Delta T = T_f - T_o = \underline{\hspace{2cm}} ^\circ C$$

$$D_o = \underline{\hspace{2cm}} mm$$

$$D_f = \underline{\hspace{2cm}} mm$$

$$\Delta \ell = D_f - D_o = \underline{\hspace{2cm}} mm \equiv \underline{\hspace{2cm}} m$$

$$\alpha_{Al} = \frac{\Delta \ell}{\ell_o \Delta T} = \underline{\hspace{2cm}} \text{ per } ^\circ C$$

$$\% \text{ Error} = \underline{\hspace{2cm}}$$

Note: the accepted value for the coefficient of linear expansion of aluminum is

$$\alpha_{Al, \text{accepted}} = 0.000022 \text{ per } ^\circ C .$$

Appendices for PHY2053L

Graphs

You will on occasion be asked to graph your data. Graphs are an extremely important part of the scientific process. I want to give you some idea of what I expect to see on the graphs that you do for this lab.

First, I will ask you to create a graph of something **versus** something else. Whatever quantity appears first--the something--is to be graphed on the **vertical axis**, while the second quantity--the something else--is to be graphed on the horizontal axis. For example, if I were to ask you to graph the period squared **versus** mass, then on the vertical axis would be the period squared, while on the horizontal axis would be the mass.

I think maybe the best way for me to explain what it is that I want is to do an example. If one suspends a mass from the end of vertical spring, it will stretch the spring. If one were to pull this mass down a little bit further and then release the mass, it would oscillate up and down. There would be a pattern, however, to this motion, and it would take the same amount of time--each time--to go up and down. This constant time is called the period of the motion and I give it the symbol τ . (We will do an experiment where we see how this time depends on the mass that we hang from the spring.) Assume that we get the following data after having done such an experiment.

M (mass)	τ (period)	τ^2
0.200 kg	0.726 s	0.526 s ²
0.300 kg	0.889 s	0.790 s ²
0.400 kg	1.026 s	1.053 s ²
0.500 kg	1.147 s	1.316 s ²
0.600 kg	1.257 s	1.579 s ²

It is highly likely that I would ask you to graph the period squared versus the mass as I have done below. Note the salient features of this graph that you, of course, will incorporate into your graphs. First, there should be a title to the graph. Also, each axis should be labeled telling what is graphed along that axis and the units of the measured quantity--represented in the parentheses. The scale on each axis should also be clearly indicated.

Usually, the graphs will involve straight lines. As the data is not exact, the data points do not form an exactly straight line. You are to try and draw a straight line that "best fits" the data plotted. This is not an exact process, so do the best you can. A best fit will try to be as close to as many of the data points as possible.

The reason we are interested in straight lines is that we understand them well. For example, we know that a straight line has the mathematical form

$$y = mx + b \quad , \quad (1)$$

where y is plotted on the vertical axis, x is plotted on the horizontal axis, m is the slope of the line, and b is the value at which the line crosses the y -axis--the so-called y -intercept. For the graph that I have shown below, note that the slope of this line can be found by using

$$m \equiv \frac{\text{change in vertical}}{\text{change in horizontal}} = \frac{\Delta(\tau^2)}{\Delta(M)} \quad . \quad (2)$$

*The Period Squared Versus The Mass
For A Mass Oscillating On A Spring*

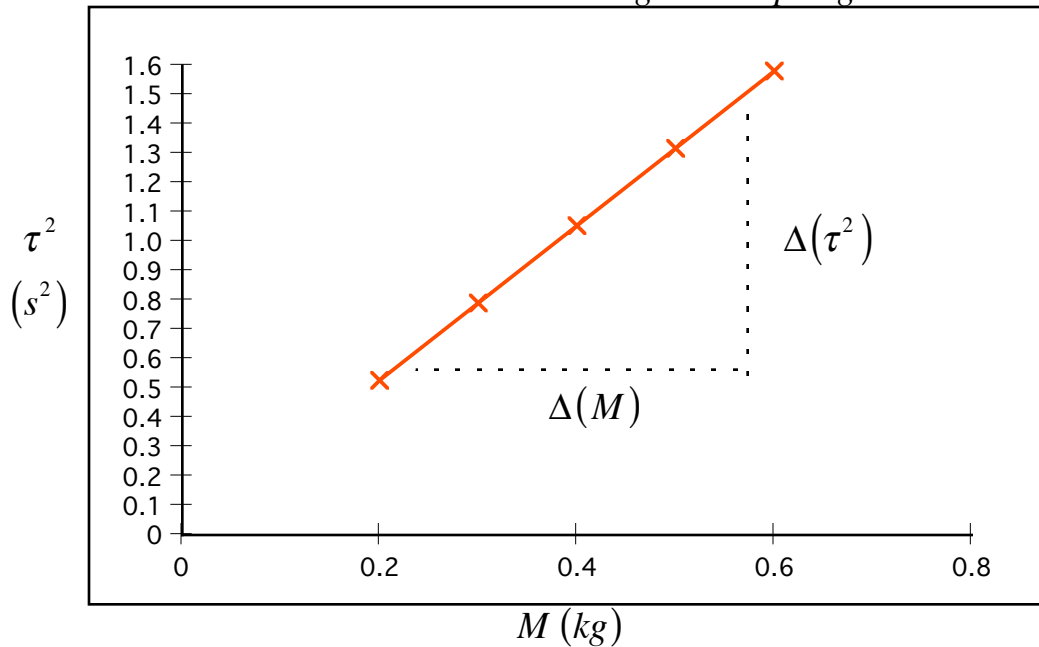

It turns out that the relationship between the period of a mass on a spring and the mass itself is given by

$$\tau = 2\pi \sqrt{\frac{M}{k_{sp}}} , \quad (3)$$

where k_{sp} is the so-called spring constant that tells us how stiff the spring is. Note, however that if we graphed the period versus the mass, we would not get a straight line. So, we graph the period squared versus the mass and do get a straight line.

$$\tau^2 = \left[\frac{4\pi^2}{k_{sp}} \right] M . \quad (4)$$

In this form, the τ^2 acts like the y value, while the M acts like the x value, with $b = 0$, and the slope is equal to

$$m = \left[\frac{4\pi^2}{k_{sp}} \right] . \quad (5)$$

However, as we saw with equation (2) we can also measure the slope directly off of the graph. So, we can use this to find the spring constant k_{sp} . We have

$$k_{sp} = \left[\frac{4\pi^2}{m} \right] . \quad (6)$$

There are many values in physics that can be measured indirectly like this--using the slope of a graph of **other** directly measured values.

Method of Least Squares

Although one can use a graph to determine the slope of a line, this method is only as good as the “eye” of the person constructing the “best fit” of the data. There is another, better way. It is called the method of least squares.

Recall that the slope-intercept form for the equation of a straight line is given by

$$y = mx + b . \quad (7)$$

Assume we have made N measurements of y and x . Then we will have N equations of the form

$$\begin{aligned} y_1 &= mx_1 + b \\ y_2 &= mx_2 + b \\ y_3 &= mx_3 + b \\ &\vdots \\ y_N &= mx_N + b \end{aligned} \quad (8)$$

Adding the equations listed in equation (8) gives us

$$\sum_{i=1}^N y_i = m \sum_{i=1}^N x_i + Nb , \quad (9)$$

Now, if we multiply each of the equations listed in (8) by its x value, we have

$$\begin{aligned} x_1 y_1 &= mx_1^2 + bx_1 \\ x_2 y_2 &= mx_2^2 + bx_2 \\ x_3 y_3 &= mx_3^2 + bx_3 \\ &\vdots \\ x_N y_N &= mx_N^2 + bx_N \end{aligned} \quad (10)$$

Adding the equations listed in (10) gives us

$$\sum_{i=1}^N x_i y_i = m \sum_{i=1}^N x_i^2 + b \sum_{i=1}^N x_i . \quad (11)$$

First, if we solve equation (9) for b . We have

$$b = \frac{1}{N} \left[\sum_{i=1}^N y_i - m \sum_{i=1}^N x_i \right] . \quad (12)$$

Substitution of equation (12) into equation (11) yields

$$\begin{aligned} \sum_{i=1}^N x_i y_i &= m \sum_{i=1}^N x_i^2 + \left\{ \frac{1}{N} \left[\sum_{i=1}^N y_i - m \sum_{i=1}^N x_i \right] \right\} \sum_{i=1}^N x_i \\ &= m \sum_{i=1}^N x_i^2 + \frac{1}{N} \left\{ \sum_{i=1}^N y_i \sum_{i=1}^N x_i - m \sum_{i=1}^N x_i \sum_{i=1}^N x_i \right\} = m \sum_{i=1}^N x_i^2 + \frac{1}{N} \sum_{i=1}^N y_i \sum_{i=1}^N x_i - \frac{m}{N} \left[\sum_{i=1}^N x_i \right]^2 . \end{aligned} \quad (13)$$

Isolating the terms with the slope m , we have

$$\sum_{i=1}^N x_i y_i - \frac{1}{N} \sum_{i=1}^N y_i \sum_{i=1}^N x_i = m \sum_{i=1}^N x_i^2 - \frac{m}{N} \left[\sum_{i=1}^N x \right]^2, \quad (14)$$

so that

$$m = \frac{\sum_{i=1}^N x_i y_i - \frac{1}{N} \sum_{i=1}^N y_i \sum_{i=1}^N x_i}{\sum_{i=1}^N x_i^2 - \frac{1}{N} \left[\sum_{i=1}^N x \right]^2} = \frac{N \sum_{i=1}^N x_i y_i - \sum_{i=1}^N y_i \sum_{i=1}^N x_i}{N \sum_{i=1}^N x_i^2 - \left[\sum_{i=1}^N x \right]^2}. \quad (15)$$

Now that we have the slope, we can find the intercept. Using equation (12), we have

$$b = \frac{1}{N} \sum_{i=1}^N y_i - \frac{m}{N} \sum_{i=1}^N x_i. \quad (16)$$

The Greek Alphabet

A	α	alpha	N	ν	nu
B	β	beta	Ξ	ξ	xi
Γ	γ	gamma	O	o	omicron
Δ	δ	delta	Π	π	pi
E	ϵ	epsilon	P	ρ	rho
Z	ζ	zeta	Σ	σ, ς	sigma
H	η	eta	T	τ	tau
Θ	θ	theta	Y	υ	upsilon
I	ι	iota	Φ	φ, ϕ	phi
K	κ	kappa	X	χ	chi
Λ	λ	lambda	Ψ	ψ	psi
M	μ	mu	Ω	ω	omega

Values of Some Physical Constants

Universal Physical Constants:

Quantity	Symbol	Value	MKS Units
Speed of light in vacuum	c	2.99792458×10^8	m / s
Permittivity of free space	ϵ_o	$8.854187187 \times 10^{-12}$	C^2 / Nm^2
Permeability of free space	μ_o	$4\pi \times 10^{-7}$	Ns^2 / C^2
Gravitational Constant	G	6.674×10^{-11}	Nm^2 / kg^2
Planck's Constant	h	6.62607×10^{-34}	Js
Charge on an electron	$-e$	$-1.602177 \times 10^{-19}$	C
Mass of an electron	m_e	9.10938×10^{-31}	kg
Charge on a proton	e	1.602177×10^{-19}	C
Mass of the proton	m_p	1.67262×10^{-27}	kg
Mass of the neutron	m_n	1.67493×10^{-27}	kg

Some Other Useful Physical Values:

Quantity	Symbol	Value	MKS Units
Mass of the Sun	M_{\odot}	1.99×10^{30}	kg
Radius of the Sun	R_{\odot}	6.96×10^8	m
Luminosity of the Sun	L_{\odot}	3.9×10^{24}	W
Mass density of the Sun	ρ_{\odot}	1,410	kg / m^3
Mass of the Earth	M_{\oplus}	5.97×10^{24}	kg
Radius of the Earth	R_{\oplus}	6.378×10^6	m
Mass density of the Earth	ρ_{\oplus}	5,520	kg / m^3
Mean Distance of the Earth from the Sun		1.496×10^{11}	m ($\equiv 1 AU$)
Mass of the Moon	M_M	7.35×10^{22}	kg
Radius of the Moon	R_M	1.74×10^6	m
Mass density of the Moon	ρ_M	3,340	kg / m^3
Mean Distance of the Moon from the Earth		3.84×10^8	m
Avogadro's Number	N_A	6.02×10^{23}	$mole^{-1}$
Atomic mass unit	u	1.66×10^{-27}	kg
Atmospheric pressure	atm	1.01×10^5	N / m^2

Quantity	Symbol	Value	MKS Units
Density of dry air at $(0^\circ\text{C}, 1\text{atm})$	ρ_{air}	1.29	kg / m^3
Molecular mass of air		0.02898	kg / mole
Speed of sound in air at $(0^\circ\text{C}, 1\text{atm})$		331	m / s
Density of water	ρ_{H_2O}	1000	kg / m^3
Earth's surface gravity	g	9.806	m / s^2